



THORVIK®

RELIABLE TOOLS



CATALOG 2021

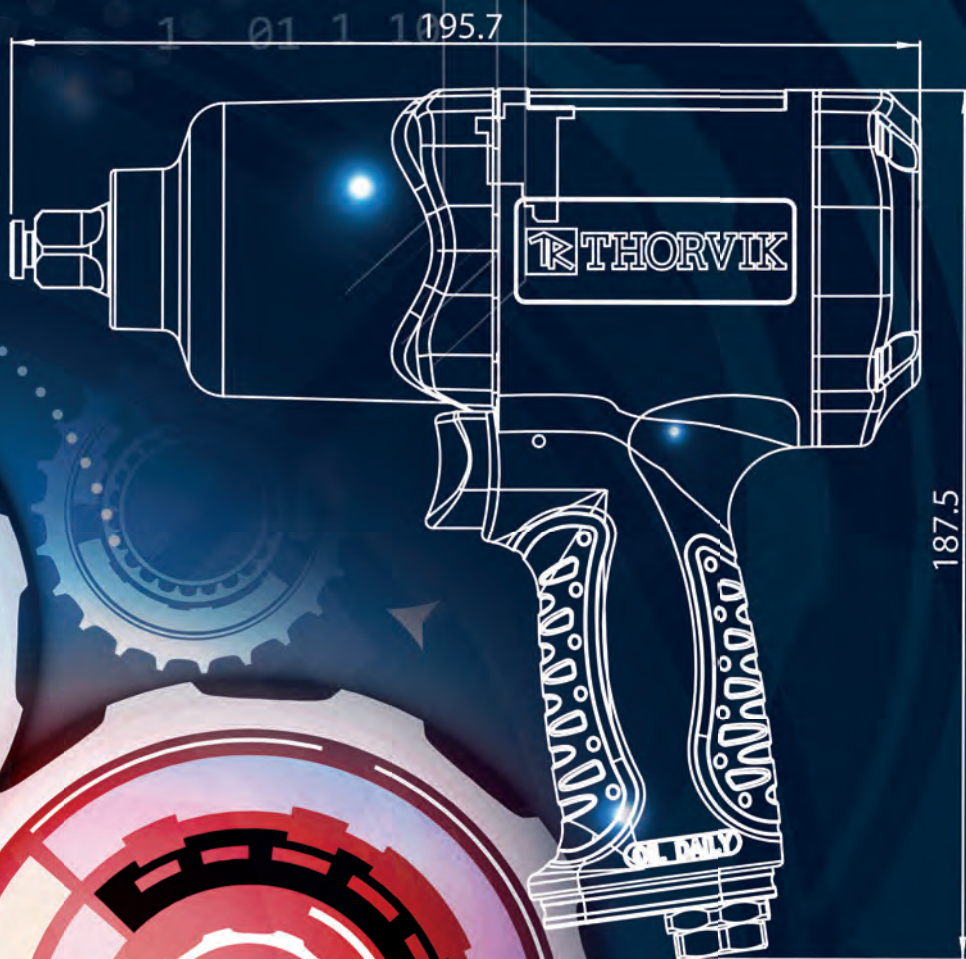

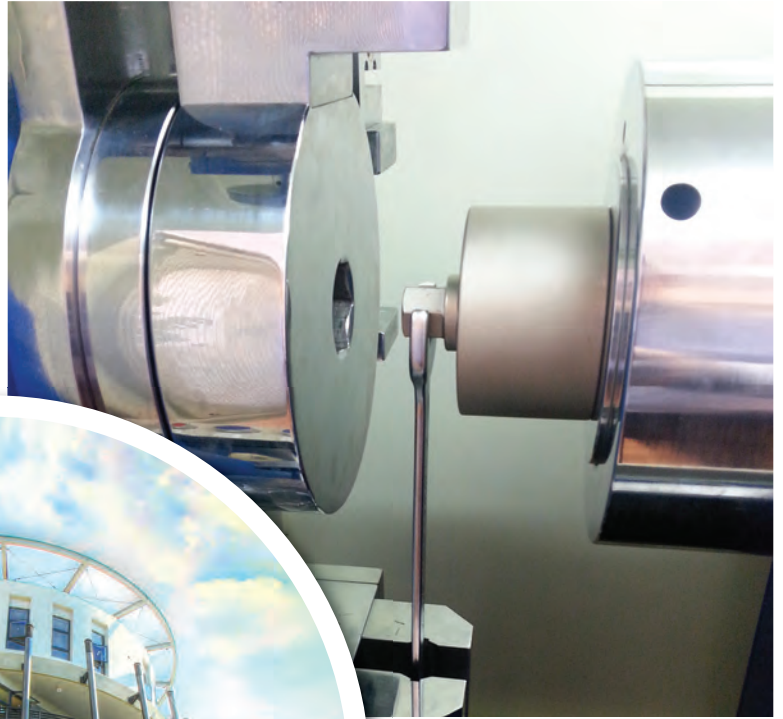





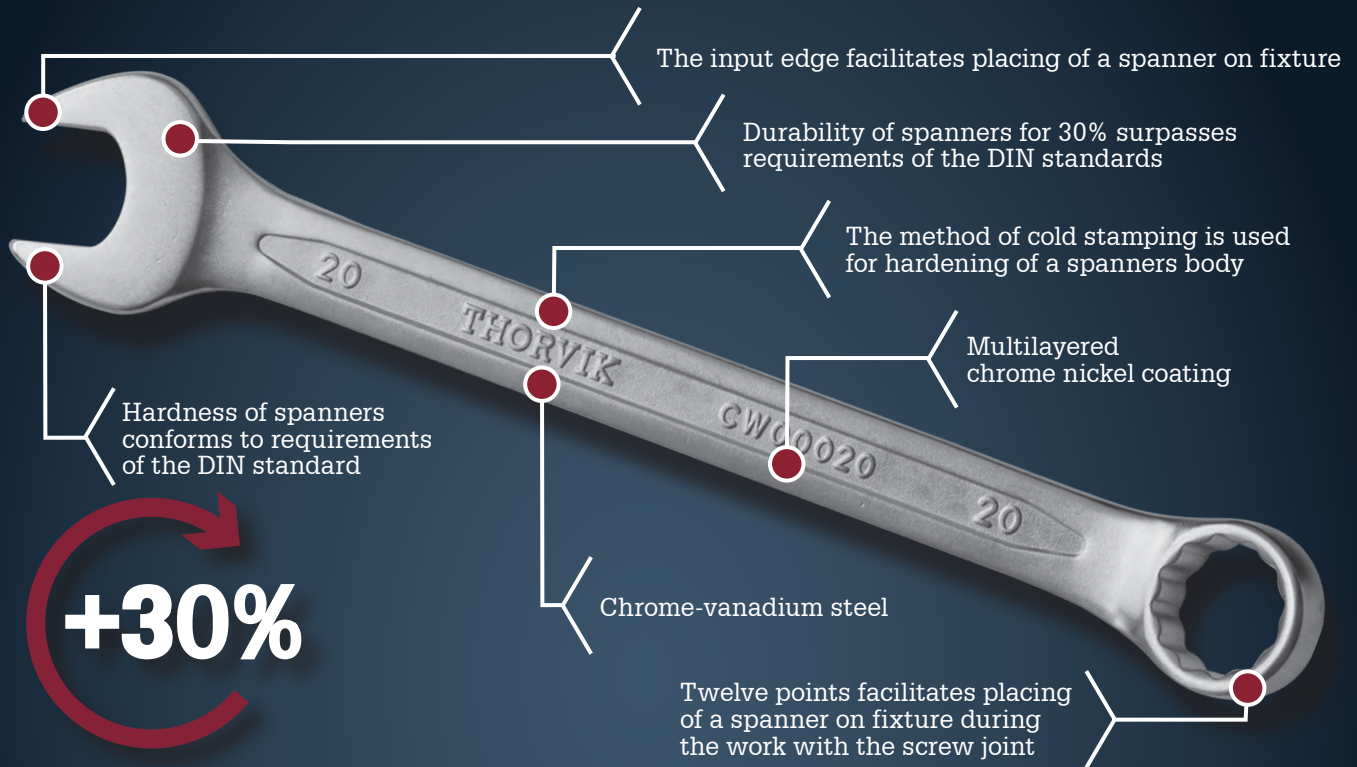

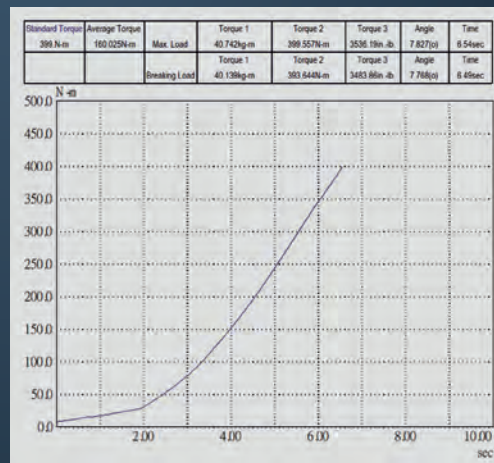
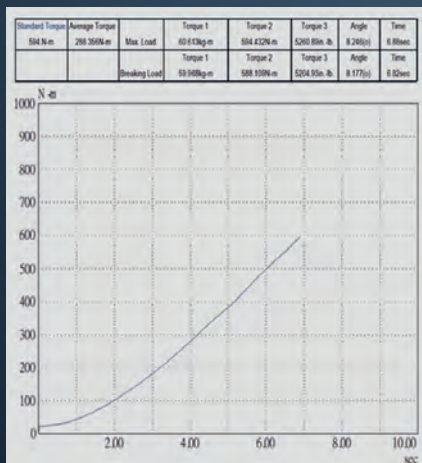

Spanners

THORVIK® spanners are produced of modern materials and under the technologies meeting strict requirements of the international standards. Habitual double-T section of handles, electroplated coating, steady against aggressive and mechanical influences, a variety of scopes, width of a size range, convenient storage of sets, reliability and durability makes the THORVIK® tools the worthy assistant to the operator.



Test reports:



Cr-V Chrome-vanadium steel	DIN According to DIN standards	DIN5234 Form A According to DIN5234 Form A	 Adjustable working part	DIN5234 Form C According to DIN5234 Form C
12 Ring part	 Open end part	 Flare nut	45° The angle of the working surfaces - 45°	 Grip type
 Shape cuts working parts	TYPE F The shape of the jaws of the working part is straight	TYPE S The shape of the jaws of the working part is curved	90° The angle of the working surfaces - 90°	
 Weight of one item	 Quantity in the package / shipping box	 Packing weight (gross) / shipping box (gross)		

COMBINATION WRENCHES AND SETS OF THEM

The most widespread and popular type of a wrench combining open-end and ring-end characteristics in a design. Use of two one-dimensional profiles does the tool universal in use. Wrenches are made of the alloyed chrome-vanadium steel according to the DIN 3113 standard.

Combination wrenches

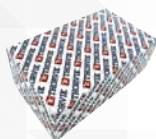
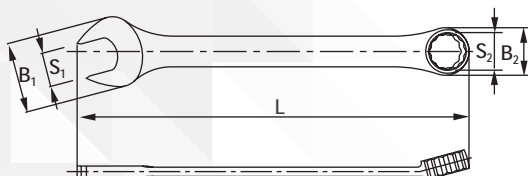

Code	Item No.	S1=S2, mm	B1, mm	B2, mm	L, mm	kg	pcs	kg
52020	CW00006	6	15	10	100	0,015	100/800	1,60/14
52021	CW00007	7	16	11	110	0,02	100/800	2,10/18
52022	CW00008	8	18	13	115	0,025	100/600	2,70/17
52023	CW00009	9	20	14	125	0,03	100/600	3,20/21
52024	CW00010	10	22	15	135	0,35	100/400	3,80/16
52025	CW00011	11	24	17	145	0,45	50/300	2,30/15
52026	CW00012	12	26	18	155	0,06	50/300	2,90/18
52027	CW00013	13	28	19	165	0,07	50/300	3,70/23
52028	CW00014	14	30	21	172	0,08	50/200	4,00/17
52029	CW00015	15	32	22	185	0,1	50/200	5,00/21
52030	CW00016	16	33	24	194	0,115	50/200	5,75/24
52031	CW00017	17	35	25	210	0,125	50/200	6,30/26
52032	CW00018	18	37	27	219	0,15	25/100	3,75/16
52033	CW00019	19	40	28	229	0,16	25/100	4,00/17
52034	CW00020	20	42	29	240	0,183	25/100	4,50/19
52035	CW00021	21	43	30	244	0,205	25/100	5,00/21
52036	CW00022	22	45	32	248	0,215	25/100	5,50/23
52037	CW00023	23	47	34	258	0,245	10/80	2,63/22
52038	CW00024	24	49	35	269	0,26	10/80	2,63/22
52039	CW00025	25	50	36	281	0,285	10/60	3,20/20
52040	CW00026	26	53	38	288	0,3	10/60	3,50/22
52041	CW00027	27	54	39	298	0,35	10/60	3,50/22
52042	CW00028	28	56	40	308	0,37	10/40	4,50/19
52043	CW00030	30	60	42	328	0,435	10/40	4,50/19
52044	CW00032	32	63	45	348	0,56	10/40	5,75/24

Combination wrench sets

Combination wrench sets in bags

14 pcs



16 pcs



Code	Item No.	kg	pcs	kg
52047	CWS0014	2,75	1/8	2,75/25
Content: 10, 11, 12, 13, 14, 16, 17, 19, 21, 22, 24, 27, 30, 32 mm				

Code	Item No.	kg	pcs	kg
52048	CWS0016	1,50	1/12	1,50/21
Content: 6, 7, 8, 9, 10, 11, 12, 13, 14, 15, 16, 17, 18, 19, 22, 24 mm				

25 pcs



Code	Item No.	kg	pcs	kg
52049	CWS0025	4,50	1/4	4,50/20
Content: 6, 7, 8, 9, 10, 11, 12, 13, 14, 15, 16, 17, 18, 19, 20, 21, 22, 23, 24, 25, 26, 27, 28, 30, 32 mm				

Combination wrenches set on a plastic holder

8 pcs

CLASSIC SERIES

Code	Item No.	kg	pcs	kg
52045	CWS0008	0,63	4/24	2,50/19

Content: 8, 9, 10, 12, 13, 14, 17, 19 mm

12 pcs

CLASSIC SERIES

Code	Item No.	kg	pcs	kg
52046	CWS0012	1,00	4/16	4,00/21

Content: 6, 7, 8, 10, 12, 13, 14, 15, 16, 17, 19, 22 mm

Combination wrenches "ARC"

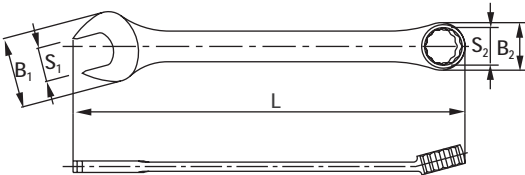

Code	Item No.	S1=S2, mm	B1, mm	B2, mm	L, mm	kg	pcs	kg
52515	W30006	6	14,80	10,70	100,00	0,020	500	11,4
52516	W30007	7	15,95	12,20	109,00	0,025	500	13,8
52517	W30008	8	18,35	12,90	119,00	0,028	500	15,1
52518	W30009	9	20,40	14,30	129,00	0,034	500	18,2
52519	W30010	10	22,35	15,50	139,00	0,041	400	17,2
52520	W30011	11	25,50	17,35	149,00	0,048	300	16,2
52521	W30012	12	27,00	18,70	159,00	0,062	300	19,8
52522	W30013	13	27,10	19,80	168,00	0,078	250	20,9
52523	W30014	14	30,90	21,75	179,00	0,085	200	19,2
52524	W30015	15	32,10	22,10	189,00	0,094	150	16,5
52525	W30016	16	35,10	23,70	199,00	0,115	100	12,5
52526	W30017	17	37,20	25,60	209,00	0,128	100	14,2
52527	W30018	18	38,65	26,80	219,00	0,145	100	15,7
52528	W30019	19	40,80	28,65	229,00	0,162	100	17,9
52529	W30020	20	42,85	29,70	238,00	0,162	100	17,9
52530	W30021	21	45,40	31,65	248,00	0,215	75	18,2
52531	W30022	22	46,95	32,10	259,00	0,240	50	13,4
52532	W30023	23	46,45	31,95	259,00	0,250	50	13,5
52533	W30024	24	51,10	34,25	275,00	0,290	50	15,6
52534	W30025	25	52,30	35,75	280,00	0,330	50	18,5
52535	W30026	26	54,30	37,70	290,00	0,356	50	19,1
52536	W30027	27	56,40	40,10	309,00	0,435	40	18,2
52537	W30028	28	57,00	41,25	324,00	0,460	40	18,9
52631	W30029	29	60,00	43,00	335,00	0,493	40	20,7
52538	W30030	30	61,90	42,65	336,00	0,527	30	16,8
52539	W30032	32	63,70	45,95	346,00	0,600	30	19
52540	W30034	34	67,24	49,83	426,20	0,900	20	18,5
52541	W30036	36	67,24	49,83	425,50	1,280	10	13,4
52542	W30038	38	72,87	55,23	480,60	1,100	10	11,7
52543	W30041	41	72,20	56,72	479,70	1,450	10	15,1
52544	W30046	46	96,44	70,77	585,10	1,780	10	18,4
52545	W30050	50	96,44	70,60	587,10	2,180	5	11,4

Set of combination wrenches "ARC"

Set of combination wrenches "ARC" on a plastic holder

6 pcs

ARC SERIES

Code	Item No.	kg	pcs	kg
52611	W3S6PR	0,467	30	14,7

Content: 8, 10, 12, 13, 14, 17 mm

8 pcs



Code	Item No.	kg	pcs	kg
52612	W3S8PR	0,670	20	14,1
Content: 6, 8, 10, 12, 13, 14, 17, 19 mm				

9 pcs



Code	Item No.	kg	pcs	kg
52613	W3S9PR	0,985	20	20,5
Content: 8, 10, 12, 13, 14, 15, 17, 19, 22 mm				

10 pcs



Code	Item No.	kg	pcs	kg
52627	W3S10PR	0,815	20	17,1
Content: 6, 7, 8, 10, 12, 13, 14, 15, 17, 19 mm				

12 pcs



Code	Item No.	kg	pcs	kg
52605	W3S12PR	1,040	10	11
Content: 6, 7, 8, 9, 10, 11, 12, 13, 14, 17, 19, 22 mm				

Combination wrench sets "ARC" series in a bags

12 pcs



Code	Item No.	kg	pcs	kg
52606	W3S12TB	1,030	10	11,5
Content: 6, 7, 8, 9, 10, 11, 12, 13, 14, 17, 19, 22 mm				

12 pcs



Code	Item No.	kg	pcs	kg
52604	W3S12ETB	1,290	10	14,1
Content: 6, 8, 10, 12, 13, 14, 15, 16, 17, 18, 19, 22 mm				

16 pcs



Code	Item No.	kg	pcs	kg
52607	W3S16TB	1,720	10	18,7
Content: 6, 7, 8, 9, 10, 11, 12, 13, 14, 15, 16, 17, 18, 19, 22, 24 mm				

20 pcs

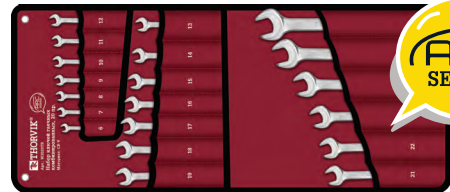

Code	Item No.	kg	pcs	kg
52608	W3S20TB	3,600	4	15,5
Content: 6, 7, 8, 9, 10, 11, 12, 13, 14, 15, 16, 17, 18, 19, 21, 22, 24, 27, 30, 32 mm				

22 pcs

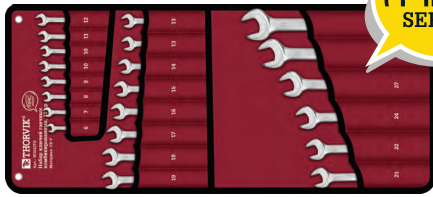

Code	Item No.	kg	pcs	kg
52609	W3S22TB	3,725	4	16
Content: 6, 7, 8, 9, 10, 10, 11, 12, 13, 13, 14, 15, 16, 17, 18, 19, 21, 22, 24, 27, 30, 32 mm				

26 pcs

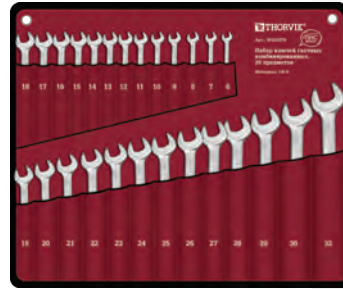

Code	Item No.	kg	pcs	kg
52610	W3S26TB	5,650	2	12,3
Content: 6, 7, 8, 9, 10, 11, 12, 13, 14, 15, 16, 17, 18, 19, 20, 21, 22, 23, 24, 25, 26, 27, 28, 29, 30, 32 mm				

Combination wrench SAE

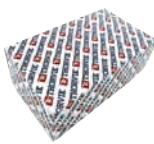
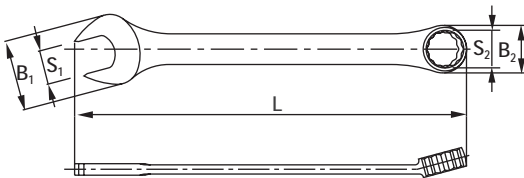

Code	Item Number	S1=S2,	B1, mm	B2, mm	L, mm	kg	pcs	kg
52902	CWI0014	1/4"	15,0	10,2	100	0,014	100/1200	1,4/16,8
52910	CWI0516	5/16"	18,0	13,0	120	0,023	100/800	2,3/18,4
52904	CWI0038	3/8"	22,0	15,8	140	0,036	100/400	3,6/14,4
52911	CWI0716	7/16"	24,5	17,2	150	0,045	100/400	4,5/18,0
52901	CWI0012	1/2"	28,5	20,0	170	0,065	50/300	3,2/19,5
52912	CWI0916	9/16"	30,5	21,5	180	0,071	50/200	3,5/14,2
52905	CWI0058	5/8"	34,5	24,0	200	0,096	25/200	2,4/19,2
52913	CWI1116	11/16"	37,5	25,5	210	0,112	25/150	2,8/16,8
52903	CWI0034	3/4"	42,0	28,0	230	0,162	25/100	4,0/16,2
52914	CWI1316	13/16"	45,0	31,5	250	0,209	25/100	5,2/20,9
52906	CWI0078	7/8"	47,0	33,0	260	0,221	25/100	5,5/22,1
52915	CWI1516	15/16"	51,0	36,0	280	0,286	10/80	2,9/22,9
52900	CWI0001	1"	53,5	37,0	290	0,307	10/60	3,1/18,4
52908	CWI0116	1-1/16"	57,5	39,5	310	0,376	10/60	3,8/22,6
52909	CWI0118	1-1/8"	59,5	42,5	330	0,436	10/40	4,4/17,4
52907	CWI0114	1-1/4"	65,5	46,5	360	0,524	10/40	5,2/21,0

Combination wrench sets SAE in bags

Combination wrench sets SAE 1/4"-15/16" in a bag

12 pcs



Code	Item No.	kg	pcs	kg
52916	CWIS0012	1,34	10	20,4
Content: 1/4", 5/16", 3/8", 7/16", 1/2", 9/16", 5/8", 11/16", 3/4", 13/16", 7/8", 15/16"				

Combination wrench sets SAE 1/4"-1.1/4" in a bag

16 pcs



Code	Item No.	kg	pcs	kg
52917	CWIS0016	2,98	4	16,93
Content: 1/4", 5/16", 3/8", 7/16", 1/2", 9/16", 5/8", 11/16", 3/4", 13/16", 7/8", 15/16", 1", 1-1/16", 1-1/8", 1-1/4"				

OPEN END WRENCHES AND SETS OF THEM

Universal tool for maintenance fasteners, available only on one side. The tools are made of chrome-vanadium steel according to DIN 3110

Open end wrenches



Cr-V

DIN

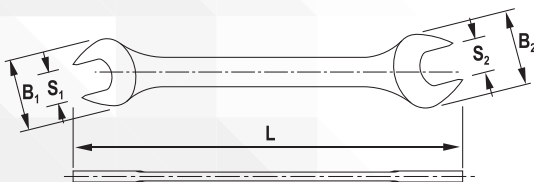

Code	Item No.	S1xS2, mm	B1, mm	B2, mm	L, mm	kg	pcs	kg
52001	OEW0607	6x7	16	17	125	0,02	100/800	2,30/20
52002	OEW0810	8x10	19	23	142	0,04	100/600	3,40/22
52003	OEW0911	9x11	21	25	155	0,05	100/400	5,00/21
52004	OEW1213	12x13	27	29	168	0,07	50/300	3,10/20
52005	OEW1417	14x17	30	36	202	0,13	50/200	5,40/25
52006	OEW1922	19x22	41	48	232	0,20	25/100	5,20/22
52007	OEW2427	24x27	51	55	262	0,31	10/60	2,85/19

Open end wrenches set

Open end wrenches set on a plastic holder

Open end wrenches set in a bag

6 pcs



7 pcs



Code	Item No.	kg	pcs	kg
52008	OEWS006	0,54	4/24	2,15/17
Content: 6x7, 8x10, 9x11, 12x13, 14x17, 19x22 mm				

Code	Item No.	kg	pcs	kg
52009	OEWS007	0,88	1/24	0,88/24
Content: 6x7, 8x10, 9x11, 12x13, 14x17, 19x22, 24x27 mm				



Open end wrenches. Series ARC



Cr-V

DIN

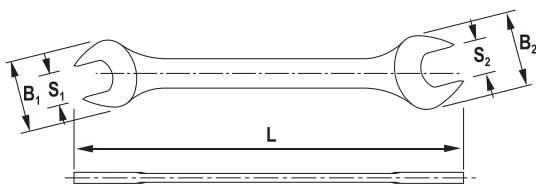

Code	Item No.	S1xS2, mm	B1, mm	B2, mm	L, mm	kg	pcs	kg
52570	W10607	6x7	10,6	12,5	178	0,023	500	12,6
52571	W10809	8x9	13,1	14,8	187	0,03	500	16,1
52572	W10810	8x10	13,5	15,1	187	0,03	500	16,1
52573	W11011	10x11	15,7	17,7	198	0,05	300	16,1
52574	W11012	10x12	15,7	17,7	198	0,05	300	16,1
52575	W11013	10x13	17,1	19,2	220	0,066	200	15,1
52576	W11213	12x13	19,4	20,4	220	0,066	200	15,1
52577	W11314	13x14	22,6	23,6	228	0,093	200	19,5
52578	W11317	13x17	25,6	26,9	242	0,124	150	19,6
52579	W11415	14x15	22,1	23,2	224	0,093	200	19,5
52580	W11416	14x16	21,9	22,6	228	0,093	200	19,5
52581	W11417	14x17	25,6	26,9	242	0,124	150	19,6
52582	W11617	16x17	24,7	25,9	242	0,124	150	19,6
52583	W11719	17x19	27,3	27,7	262	0,142	100	16,1
52584	W11819	18x19	27,3	27,7	262	0,142	100	16,1
52586	W11922	19x22	30,7	33,9	288	0,199	75	16
52587	W12022	20x22	30,7	33,9	288	0,199	75	16
52588	W12123	21x23	31,0	33,9	292	0,231	75	18,1
52589	W12224	22x24	30,5	33,8	292	0,231	75	18,1
52590	W12427	24x27	35,4	40,2	319	0,298	50	15,8
52591	W12528	25x28	37,6	41,0	362	0,376	50	19,7
52592	W12730	27x30	39,4	45,8	362	0,376	50	19,7
52593	W13032	30x32	43,0	46,0	368	0,483	30	15,3

Open end wrenches set. Series ARC

Open end wrenches set on a plastic holder. Series ARC

6 pcs



8 pcs



Code	Item No.	kg	pcs	kg
52617	W1S6PR	0,55	30	17,2
Content: 8x10, 10x12, 12x13, 14x15, 13x17, 17x19 mm				

Code	Item No.	kg	pcs	kg
52618	W1S8PR	0,77	20	16,1
Content: 6x7, 8x9, 8x10, 12x13, 14x15, 16x17, 17x19, 19x22 mm				

Open end wrenches set in a bag. Series ARC

10 pcs



Code	Item No.	kg	pcs	kg
52614	W1S10TB	1,144	16	18,9
Content: 6x7, 8x9, 8x10, 10x12, 12x13, 13x14, 14x17, 17x19, 19x22, 22x24 mm				

11 pcs



12 pcs



Code	Item No.	kg	pcs	kg
52615	W1S11TB	2,313	8	19,1
Content: 8x10, 10x12, 12x13, 14x15, 13x17, 17x19, 19x22, 22x24, 24x27, 27x30, 30x32 mm				

Code	Item No.	kg	pcs	kg
52616	W1S12TB	2,375	8	19,6
Content: 6x7, 8x9, 10x11, 12x13, 14x15, 16x17, 18x19, 20x22, 21x23, 24x27, 25x28, 30x32 mm				

DOUBLE RING END WRENCHES AND SETS OF THEM

Are applied to work with high-loaded joints, Curved 75° working part facilitates access to hard-to-reach places. The wrenches are made of alloyed chrome-vanadium steel according to DIN 838.

Double ring end wrenches

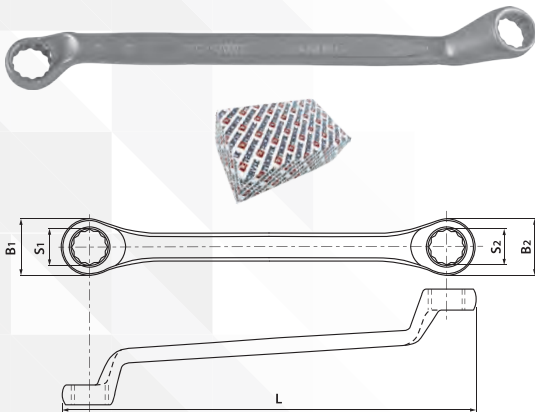

12

Cr-V

DIN



Code	Item No.	S1xS2, mm	B1, mm	B2, mm	L, mm	kg	pcs	kg
52010	ORW0607	6x7	10	11	173	0,06	100/400	5,50/23
52011	ORW0809	8x9	13	14	185	0,07	100/200	7,50/16
52012	ORW1011	10x11	16	17	197	0,09	50/200	4,75/20
52013	ORW1213	12x13	18	20	213	0,11	50/200	5,60/24
52014	ORW1415	14x15	22	23	226	0,14	25/150	4,10/26
52015	ORW1719	17x19	26	28	266	0,24	25/100	6,00/25
52016	ORW2122	21x22	31	33	288	0,30	10/60	3,00/19
52017	ORW2427	24x27	36	40	326	0,44	10/40	4,40/19

Double ring end wrenches set

Double ring end wrenches set on a plastic holder

6 pcs

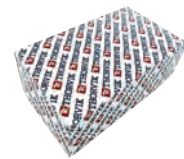

Code	Item No.	kg	pcs	kg
52018	ORWS006	0,80	4/24	3,18/23
Content: 6x7, 8x9, 10x11, 12x13, 14x15, 17x19 mm				

Double ring end wrenches set in a bag

8 pcs



Code	Item No.	kg	pcs	kg
52019	ORWS008	1,50	1/12	1,50/21
Content: 6x7, 8x9, 10x11, 12x13, 14x15, 17x19, 21x22, 24x27 mm				

Double ring end wrenches. Series ARC



12 Cr-V DIN

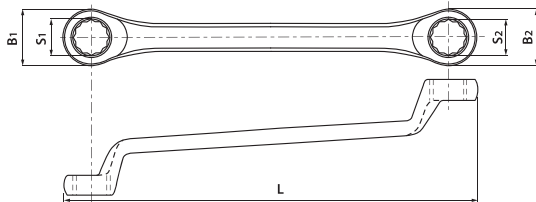

Code	Item No.	S1xS2, mm	B1, mm	B2, mm	L, mm	kg	pcs	kg
52546	W20607	6X7	14,4	16,2	123,4	0,047	300	15,2
52547	W20809	8X9	18,2	20,3	139,6	0,065	300	20,5
52548	W20810	8X10	18,5	22,7	139,6	0,065	300	20,5
52549	W21011	10X11	22,9	26,6	156,7	0,096	200	20,3
52550	W21012	10X12	22,8	26,7	157,3	0,096	200	20,3
52551	W21013	10X13	22,8	27,8	156,8	0,108	200	22,6
52552	W21213	12X13	27,7	29,5	171,8	0,108	200	22,6
52553	W21314	13X14	30,6	33,6	187,8	0,148	150	23,2
52554	W21317	13X17	30,1	35,8	204,0	0,168	100	18,1
52555	W21415	14X15	29,2	31,7	188,2	0,148	150	23,2
52556	W21416	14X16	28,8	35,1	204,7	0,148	150	23,2
52557	W21417	14X17	29,9	35,5	204,4	0,168	100	18,1
52558	W21617	16X17	34,3	36,3	203,9	0,168	100	18,1
52559	W21719	17X19	37,6	39,4	220,8	0,236	75	18,8
52560	W21819	18X19	37,4	39,0	220,7	0,236	75	18,8
52562	W21922	19X22	40,6	44,5	235,5	0,305	75	23,9
52563	W22022	20X22	40,6	44,5	235,5	0,305	75	23,9
52564	W22123	21X23	42,4	46,9	244,8	0,34	50	18
52565	W22224	22X24	44,4	48,4	245,3	0,34	50	18
52566	W22427	24X27	48,9	52,9	263,9	0,408	40	17,5
52567	W22528	25X28	51,9	56,8	274,2	0,46	40	19,4
52568	W22730	27X30	51,9	56,8	274,2	0,46	40	19,4
52569	W23032	30X32	60,1	63,4	299,1	0,583	30	18,6

Double ring end wrenches set. Series ARC

Double ring end wrenches set on a plastic holder. Series ARC



Code	Item No.	kg	pcs	kg
52621	W2S6PR	0,865	20	18

Content: 8x9, 10x11, 12x13, 14x15, 16x17, 18x19 mm



Code	Item No.	kg	pcs	kg
52622	W2S8PR	1,240	10	13,1

Content: 6x7, 8x9, 10x11, 12x13, 14x15, 16x17, 18x19, 20x22 mm

Double ring end wrenches set in a bag. Series ARC



Code	Item No.	kg	pcs	kg
52623	W2S8TB	1,250	10	14,2

Content: 6x7, 8x10, 10x12, 12x13, 13x14, 14x17, 17x19, 19x22 mm

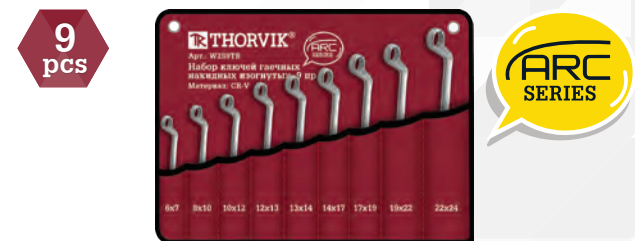

Code	Item No.	kg	pcs	kg
52624	W2S9TB	1,600	10	17,8

Content: 6x7, 8x10, 10x12, 12x13, 13x14, 14x17, 17x19, 19x22, 22x24 mm

10 pcs



12 pcs



Code	Item No.	kg	pcs	kg
52619	W2S10TB	2,025	8	18
Content: 6x7, 8x9, 10x11, 12x13, 14x15, 16x17, 18x19, 20x22, 21x23, 24x27 mm				

Code	Item No.	kg	pcs	kg
52620	W2S12TB	3,217	6	20,8
Content: 6x7, 8x9, 10x11, 12x13, 14x15, 16x17, 18x19, 20x22, 21x23, 24x27, 25x28, 30x32 mm				

DOUBLE END FLARE NUT WRENCHES AND SETS OF THEM

Combine in their design the ability to transmit high loads, like a ring end wrench, with the convenience of open end wrench. Flare nut wrenches are used primarily for maintenance of pipe fittings, when the use of an open-end wrench can damage a joint, and it is not possible to apply a ring end wrench or flank socket. The tools are made of vanadium steel according to DIN 3118.

Double end flare nut wrenches



Cr-V

DIN

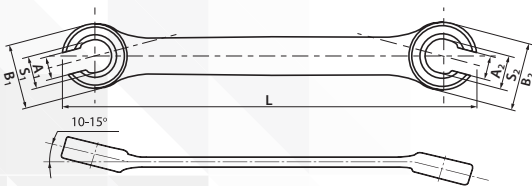

Code	Item No.	S1xS2, mm	B1xB2, mm	A1xA2, mm	L, mm	kg	pcs	kg
52050	FNW0810	8x10	16x18	6x7	142	0,05	100/400	4,50/19
52051	FNW1012	10x12	18x20	7x9	145	0,07	50/200	2,50/11
52052	FNW1113	11x13	20x24	8x10	164	0,08	50/200	3,75/16
52053	FNW1214	12x14	21x25	9x11	175	0,11	50/200	4,50/19
52054	FNW1719	17x19	29x32	14x15	202	0,18	25/100	4,75/20

Double end flare nut wrenches set

Double end flare nut wrenches set in a bag

5 pcs

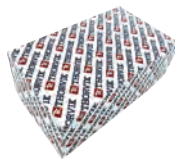

Code	Item No.	kg	pcs	kg
52055	FNWS005	0,47	1/30	0,47/17
Content: 8x10, 10x12, 11x13, 12x14, 17x19 mm				

Double end flare nut wrenches. Series ARC



Cr-V

DIN

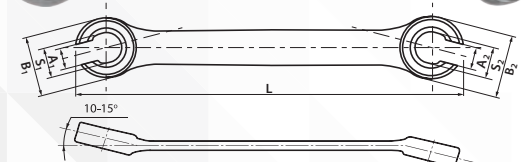

Code	Item No.	S1xS2, mm	B1xB2, mm	A1xA2, mm	L, mm	kg	pcs	kg
52594	W40608	6x8	12,6x14,3	3,37x6,27	119,16	0,025	600	16,1
52595	W40810	8x10	14,0x17,4	6,70x7,85	139,5	0,045	400	19,7
52596	W40911	9x11	17,3x22,1	7,20x7,68	160,19	0,05	400	21,7
52597	W41012	10x12	17,5x21,8	7,84x9,41	159,02	0,055	400	23,7
52598	W41314	13x14	23,5x25,8	10,2x10,9	169,39	0,0752	250	20
52599	W41517	15x17	27,2x28,9	11,6x13,3	186,67	0,106	200	22,3
52600	W41618	16x18	28,2x30,5	12,6x13,8	206,82	0,13	150	20,4
52601	W41921	19x21	32,4x38,0	14,3x16,0	225,99	0,205	100	21,6

Double end flare nut wrenches set. Series ARC

Double end flare nut wrenches set in a bag. Series ARC

4 pcs



7 pcs



Code	Item No.	kg	pcs	kg
52625	W4S4TB	0,292	50	16,6
Content: 8x10, 9x11, 12x13, 15x17 mm				

Code	Item No.	kg	pcs	kg
52626	W4S7TB	0,570	30	18,8
Content: 8x10, 9x11, 10x11, 12x13, 13x14, 15x17, 17x19 mm				

ADJUSTABLE WRENCHES

The range of adjustable Thorvik wrenches includes seven standard sizes providing service of joint elements in the big range. Tools are manufactured of alloyed high-quality chrome-vanadium steel according to the DIN 3117 standard. Thorvik adjustable wrenches are supplied with exact details of mechanism of jaws that provides the minimum working gaps and smooth adjustment. Products have a protective phosphate coating with a metric dimensional scale.

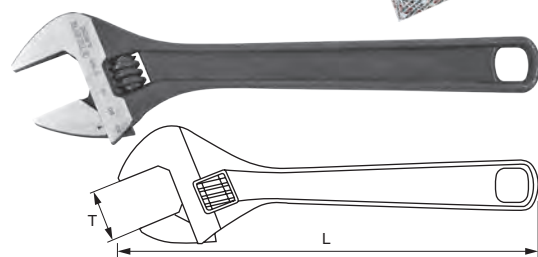

Code	Item No.	L, mm	T, mm	kg	pcs	kg
52251	AJW100	100	13	0,06	10/200	0,80/15
52252	AJW150	150	22	0,132	6/96	0,94/15
52253	AJW200	200	27	0,24	6/60	1,60/16
52254	AJW250	250	30	0,42	6/48	2,75/22
52255	AJW300	300	34	0,662	6/36	4,33/26
52256	AJW375	375	46	1,39	6/18	9,00/27
52257	AJW450	450	52	1,632	2/12	3,67/22

Technological stages for the production of THORVIK® wrenches:

- STAGE №1 - Cutting of primary preform
- STAGE №2 - Forging and pressing processing (hot stamp)
- STAGE №3 - Felling
- STAGE №4 - Primary formation of working surfaces
- STAGE №5 - Formation of working surfaces (broaching) + primary polishing
- STAGE №6 - Marking. Heat treatment
- STAGE №7 - Vibration-abrasive polishing. Grinding
- STAGE №8 - Electroplating

PIPE WRENCHES

Pipe wrenches are universal tools. Thanks to a special design of gripping allow to serve not only round details, but also the profiled threaded fasteners.

F-type with jaws under 90°

Induction hardened to high hardness jaws with an angle of inclination of the teeth, which allows you to achieve the maximum possible grip force.

S-shaped jaws allow servicing of pipes and fasteners of various profiles.

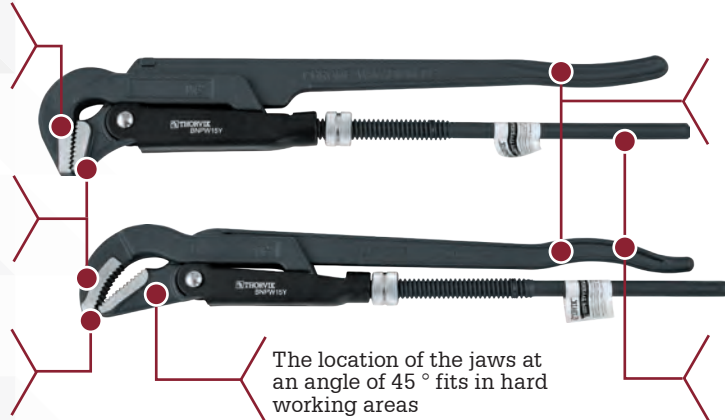



The tools are made of alloy chrome-vanadium steel, according to standards 5234 (Form A, C).

The location of the jaws at an angle of 45° fits in hard working areas

Matte protective coating prevents the appearance of chips on the tool body

Pipe wrenches. F type

 DIN5234 Form A

 Cr-V

TYPE
F **90°**

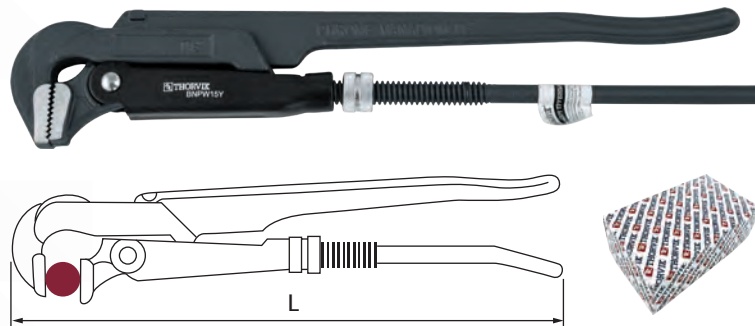

Code	Item No.	Nº	Range, mm	L, mm	kg	pcs	kg
52275	BNPW01L	1	10 - 36	300	0,83	36	31,0
52279	BNPW15L	1,5	20 - 50	400	1,35	24	33,5
52277	BNPW02L	2	20 - 63	500	2,54	12	31,5

Pipe wrenches. S type

 DIN5234 Form C

 Cr-V

TYPE
S **45°**

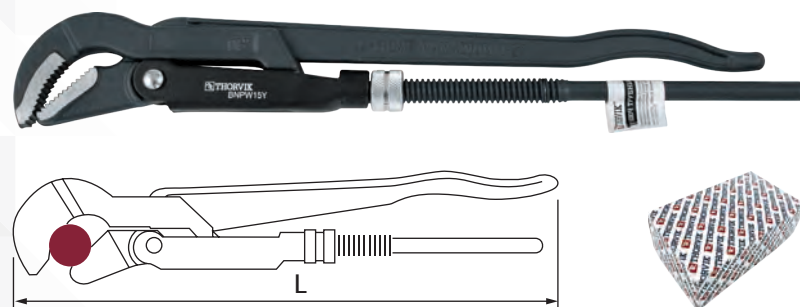

Code	Item No.	Nº	Range, mm	L, mm	kg	pcs	kg
52276	BNPW01Y	1	10 - 36	300	0,61	36	23,0
52280	BNPW15Y	1,5	20 - 50	400	1,1	24	27,5
52278	BNPW02Y	2	20 - 63	500	1,75	12	22,0

Sockets

THORVIK® sockets are manufactured using technologies that allow the transfer of forces exceeding modern standards by 30%. A wide range of sizes, types and profiles, high precision machining, high-quality chrome-vanadium steel and a steady chrome-nickel coating make the tool reliable and durable. The THORVIK® sockets are the basis for creating fitting-assembling tools. Products are made on modern equipment according to DIN 3124.

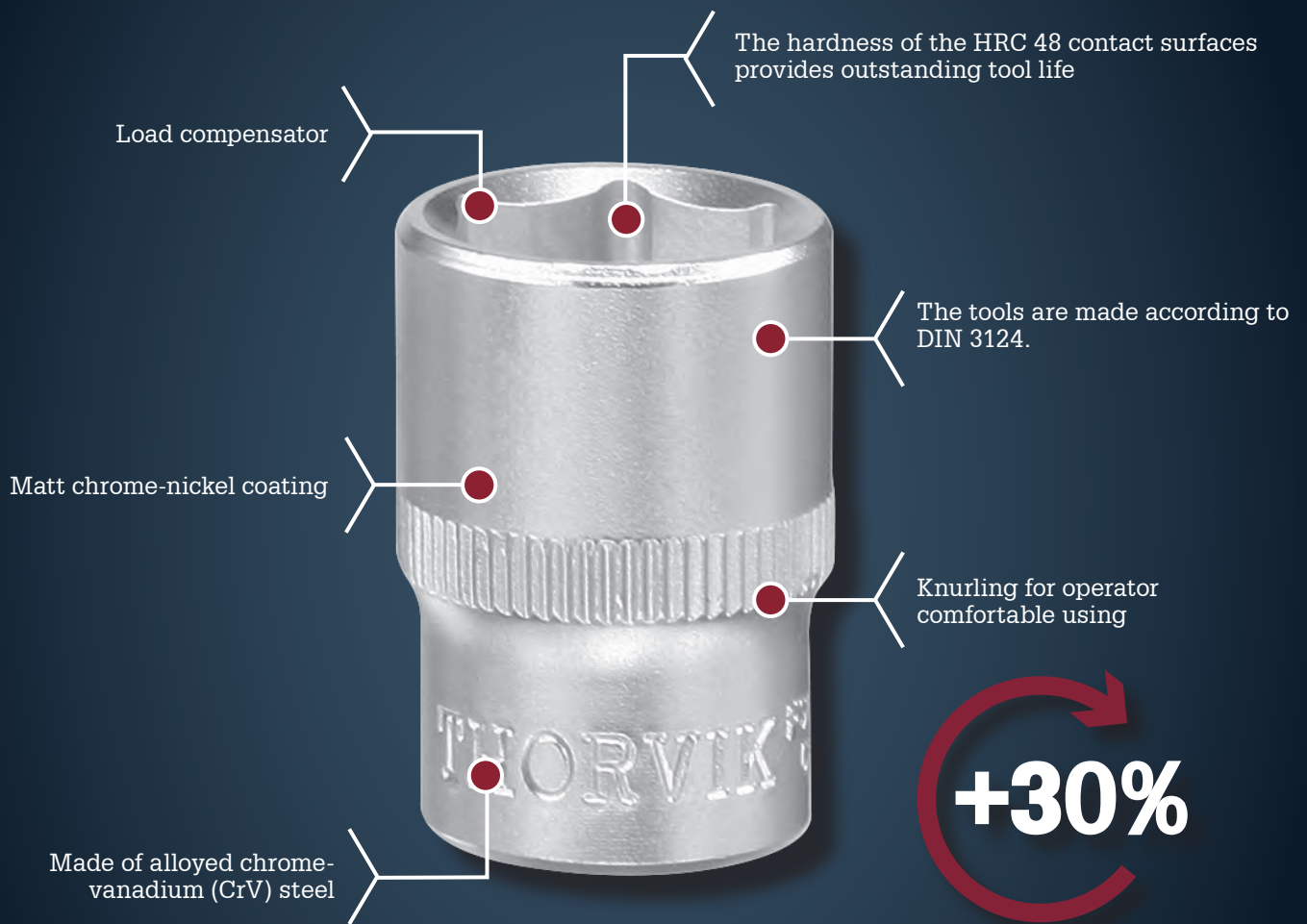

Cr-V Chrome-vanadium steel	1/2" Drive size 1/2" (inch)	DIN According to DIN standart
1/4" Drive size 1/4" (inch)	6 6 point sockets	1" Drive size 1" (inch)
4 4-point sockets	MP MP (MultiProf) sockets	12 12-point sockets

Weight of one item

Quantity in the package / shipping box

Packing weight (gross) / shipping box (gross)

FLANK SOCKETS 1/4"DR

Flank sockets 1/4"DR

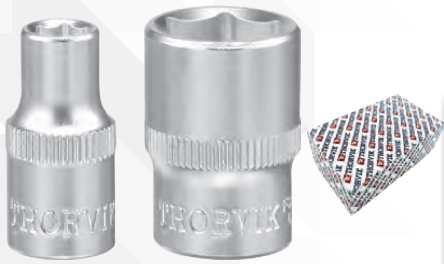

Cr-V 1/4" 6 DIN

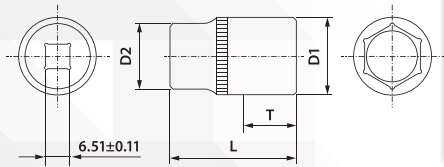

Code	Item No.	Size, mm	D2, mm	D1, mm	T, mm	L, mm	MF kgf/m	kg	pcs	kg
52064	FS01405	5	11,8	8,1	9,0	25	1,5	0,010	100 / 200	1,075 / 2,2
52065	FS01406	6	11,8	9,3	10,1	25	2,0	0,010	100 / 500	1,090 / 5,7
52066	FS01407	7	11,8	10,6	11,0	25	2,7	0,010	100 / 1000	1,185 / 12,2
52067	FS01408	8	11,4	11,9	11,1	25	3,4	0,010	100 / 1000	1,135 / 11,7
52068	FS01409	9	11,9	12,9	11,2	25	4,1	0,015	100 / 300	1,305 / 4,1
52069	FS01410	10	12,1	13,9	13,0	25	4,9	0,015	100 / 1000	1,285 / 13,2
52070	FS01411	11	14,1	15,9	13,1	25	5,8	0,020	100 / 200	1,870 / 3,9
52071	FS01412	12	15,1	16,9	13,0	25	6,7	0,020	100 / 1000	2,170 / 22,1
52072	FS01413	13	16,1	17,9	13,0	25	6,9	0,022	100 / 1000	2,375 / 24,2

Deep flank sockets 1/4"DR

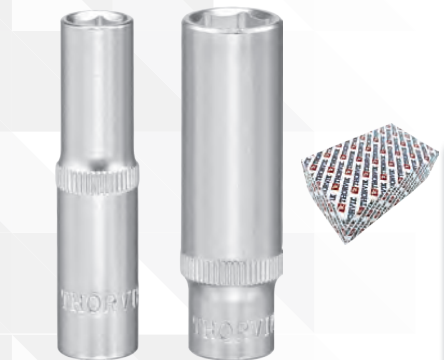

Cr-V 1/4" 6 DIN

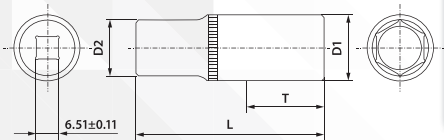

Code	Item No.	Size, mm	D2, mm	D1, mm	T, mm	L, mm	MF kgf/m	kg	pcs	kg
52073	FS11405	5	11,8	8,1	11,5	50	1,5	0,020	100 / 200	2,155 / 4,5
52074	FS11406	6	11,8	9,3	11,8	50	2,0	0,025	100 / 200	2,325 / 4,9
52075	FS11407	7	11,8	10,6	11,8	50	2,7	0,025	100 / 800	2,470 / 20,1
52076	FS11408	8	11,4	11,9	11,4	50	3,4	0,020	100 / 1000	2,380 / 24,3
52077	FS11409	9	11,9	12,9	11,8	50	4,1	0,020	100 / 200	2,935 / 6,1
52078	FS11410	10	12,1	13,9	12,5	50	4,9	0,035	100 / 600	3,635 / 22,2
52079	FS11411	11	14,1	15,9	14,1	50	5,8	0,040	100 / 200	4,225 / 8,8
52080	FS11412	12	15,1	16,9	11,5	50	6,7	0,054	100 / 300	4,710 / 14,5
52081	FS11413	13	16,1	17,9	16,1	50	6,9	0,050	100 / 400	5,160 / 21,0

12-point flank sockets 1/4"DR



Cr-V 1/4" 12 DIN

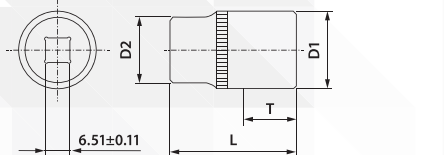

Code	Item No.	Size, mm	D2, mm	D1, mm	T, mm	L, mm	kg	pcs	kg
52963	FS21404	4	11,79	6,85	8,05	24,85	0,01	300	3,88
52964	FS21445	4.5	11,96	7,33	9,86	24,81	0,01	300	3,35
52965	FS21405	5	11,93	8,09	7,96	24,76	0,01	300	3,46
52966	FS21455	5.5	11,85	8,68	13,51	24,73	0,01	300	3,44
52967	FS21406	6	11,9	9,3	8,47	24,83	0,01	300	3,62
52968	FS21407	7	11,95	10,71	13,18	24,82	0,01	300	3,64
52969	FS21408	8	11,27	11,84	10,29	24,94	0,01	300	3,42
52970	FS21409	9	12,07	13,45	10,09	24,95	0,01	300	3,99
52971	FS21410	10	12,03	13,89	13,06	24,88	0,01	300	3,91
52972	FS21411	11	15,01	16,7	12,28	24,97	0,02	300	6,55
52973	FS21412	12	16	17,8	13,47	24,87	0,02	363	8,01
52974	FS21413	13	16,01	17,77	12,76	24,5	0,02	390	9,58
52975	FS21414	14	17,94	19,78	13,76	24,64	0,03	300	10,06

12-point deep flank sockets 1/4"DR



Cr-V 1/4" 12 DIN

Code	Item No.	Size, mm	D2, mm	D1, mm	T, mm	L, mm	kg	pcs	kg
52976	FS31406	6	11,78	10,35	14,99	50,32	0,02	200	5,16
52977	FS31407	7	11,85	10,72	22,07	49,88	0,02	200	5,07
52978	FS31408	8	11,31	11,91	20,32	49,99	0,02	200	5,01
52979	FS31409	9	11,99	13,45	17,47	49,93	0,03	200	6,5
52980	FS31410	10	12,51	14,68	20,88	49,97	0,04	200	8,5
52981	FS31411	11	21,73	16,39	13,3	37,93	0,04	300	12,98
52982	FS31412	12	12,81	17,82	13,9	37,99	0,05	300	15,6
52983	FS31413	13	21,92	18,82	14,97	38,16	0,05	300	15,32

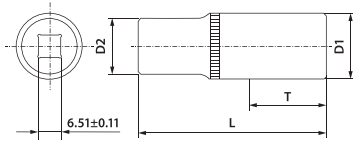

MultiProf flank sockets 1/4"DR



Cr-V 1/4" MP3 DIN

Code	Item No.	Size, mm	D2, mm	D1, mm	T, mm	L, mm	kg	pcs	kg
52920	MP01404	4	11,88	6,89	9,83	24,91	0,01	300	3,24
52921	MP01445	4.5	11,85	7,38	8,01	24,89	0,01	300	3,23
52922	MP01405	5	11,9	8,13	8,52	24,91	0,01	300	3,28
52923	MP01455	5.5	11,91	8,88	11,23	25,03	0,01	300	3,4
52924	MP01406	6	11,81	9,54	9,15	24,9	0,01	300	3,6
52925	MP01407	7	11,56	10,74	10,67	24,95	0,01	300	4,34
52926	MP01408	8	11,88	12,92	10,3	24,98	0,01	300	4,19
52927	MP01409	9	12,07	13,41	10,09	24,95	0,01	300	4,5
52928	MP01410	10	13,96	13,98	10,11	24,96	0,02	300	6,01
52929	MP01411	11	15	16,69	12,28	24,97	0,02	363	8,25
52930	MP01412	12	15,99	17,2	13,47	24,89	0,02	390	9,55
52931	MP01413	13	17,95	18,49	12,9	24,77	0,03	300	9,97
52932	MP01414	14	18,03	19,75	12,71	24,99	0,03	300	9,64

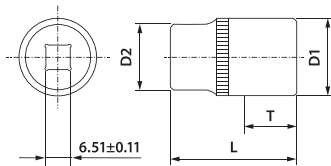

MultiProf deep flank sockets 1/4"DR

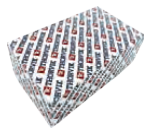

Cr-V 1/4" MP3 DIN

Code	Item No.	Size, mm	D2, mm	D1, mm	T, mm	L, mm	kg	pcs	kg
52933	MP11406	6	11,9	9,25	17,28	50,19	0,02	200	4,86
52934	MP11407	7	11,85	10,72	22,07	49,88	0,02	200	5,04
52935	MP11408	8	11,96	12,13	17,46	49,87	0,03	200	7,13
52936	MP11409	9	11,99	13,41	11,99	49,94	0,03	200	6,69
52937	MP11410	10	14	14,7	18,5	50,07	0,04	300	13,2
52938	MP11411	11	15,04	15,93	20,48	49,97	0,05	300	15,5
52939	MP11412	12	15,93	17,24	19,45	49,96	0,05	300	15,91
52940	MP11413	13	15,94	18,5	19,48	49,87	0,06	300	18,25

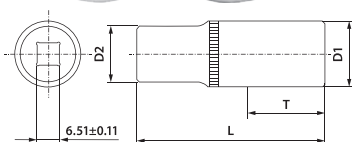

FLANK SOCKETS 1/2"DR

Flank sockets 1/2"DR

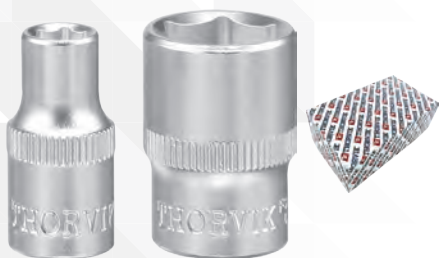

Cr-V 1/2" 6 DIN

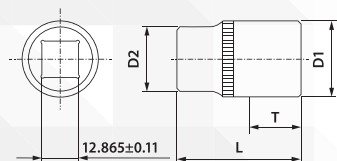

Code	Item No.	Size, mm	D2, mm	D1, mm	T, mm	L, mm	MF kgf/m	kg	pcs	kg
52089	FS01208	8	21,8	13,1	13,8	38	14,8	0,050	100/400	4,920 / 20,1
52090	FS01209	9	21,8	14,3	13,8	38	17,8	0,050	100/400	5,045 / 20,6
52091	FS01210	10	21,8	15,3	13,8	38	21,3	0,050	100/400	5,040 / 20,5
52092	FS01211	11	21,8	16,3	14,0	38	25,0	0,050	100/400	5,115 / 20,9
52093	FS01212	12	21,8	17,8	14,3	38	28,8	0,050	100/400	5,215 / 21,3
52094	FS01213	13	21,8	19,1	14,3	38	33,2	0,055	100/400	5,360 / 21,9
52095	FS01214	14	21,8	20,3	14,2	38	37,8	0,055	100/400	5,505 / 22,5
52096	FS01215	15	20,9	21,6	14,1	38	42,5	0,055	100/400	5,395 / 22,0
52097	FS01216	16	20,8	21,8	13,8	38	47,8	0,050	100/400	5,085 / 20,8
52098	FS01217	17	21,8	23,8	14,3	38	53,1	0,065	100/300	6,420 / 19,7
52099	FS01218	18	23,9	25,4	14,4	38	56,9	0,075	100/300	7,870 / 24,1
52100	FS01219	19	23,9	25,8	14,9	38	56,9	0,065	100/300	6,590 / 20,3
52101	FS01221	21	25,9	27,8	15,8	38	56,9	0,085	50/300	4,325 / 26,5
52102	FS01222	22	26,1	29,8	15,6	38	56,9	0,095	50/200	4,860 / 19,6
52103	FS01224	24	27,9	31,8	15,9	38	56,9	0,110	50/200	5,495 / 22,4
52104	FS01227	27	30,9	35,7	19,0	42	56,9	0,155	40/160	6,400 / 26,0
52105	FS01230	30	34,0	39,7	22,0	44	56,9	0,200	30/120	6,145 / 25,0
52106	FS01232	32	36,0	41,8	21,8	44	56,9	0,225	25/100	5,750 / 23,4

Deep flank sockets 1/2"DR



Cr-V 1/2" 6 DIN

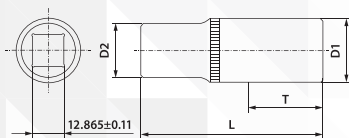

Code	Item No.	Size, mm	D2, mm	D1, mm	T, mm	L, mm	MF kgf/m	kg	pcs	kg
52107	FS11210	10	21,9	15,3	19,4	76,9	21,3	0,095	50/200	4,83/19,6
52108	FS11212	12	21,9	17,8	18,3	76,9	28,8	0,100	50/200	5,145/20,8
52109	FS11213	13	21,9	19,1	19,3	76,9	33,2	0,105	50/200	5,495/22,2
52110	FS11214	14	21,9	20,3	33,0	76,9	37,8	0,110	50/200	5,725/23,4
52111	FS11215	15	21,9	21,6	33,0	76,9	42,5	0,110	50/200	5,67/23
52112	FS11216	16	21,9	21,8	31,4	76,9	47,8	0,100	50/200	5,13/20,8
52113	FS11217	17	21,7	23,8	31,4	76,9	53,1	0,125	50/200	6,265/25,5
52114	FS11218	18	22,9	25,4	31,0	76,9	56,9	0,150	40/160	6,055/24,6
52115	FS11219	19	23,8	25,8	31,6	76,9	56,9	0,140	40/160	5,735/23,3
52116	FS11221	21	25,8	27,8	31,6	76,9	56,9	0,165	30/120	5,01/20,4
52117	FS11222	22	26,0	29,8	32,9	76,9	56,9	0,185	30/120	5,68/23,1
52118	FS11224	24	28,0	31,8	32,7	76,9	56,9	0,210	25/100	5,32/21,7

THORVIK® «MULTIPROF»

The revolutionary THORVIK® "MultiProf" system of bench-mounting tools is able to save the user from the need to purchase a large number of tools. One THORVIK® "MultiProf" nominal socket size is suitable for eight different profiles and is used for nuts and bolt heads of 6 and 12-point metric sizes, 6 and 12-point inch sizes, external TORX®, SPLINE bolts, and fasteners of three and four-points. The THORVIK® "MultiProf" system is also able to work with damaged (rounded to 30%) fasteners. The contact spot with the fasteners is distributed over a larger area, in contrast to the standard profile, which has point contact spots. The THORVIK® "MultiProf" system of bench-mounting tools has a wide range of applications: it is recommended for use in industrial plants with a high load of intensity, the organization of maintenance of aviation, automotive, agricultural, household appliances, etc.

12-point flank sockets 1/2"DR

Cr-V 1/2" 12 DIN

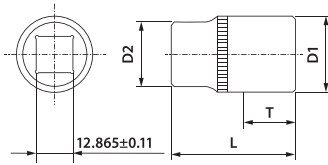

Code	Item No.	Size, mm	D2, mm	D1, mm	T, mm	L, mm	kg	pcs	kg
52984	FS21210	10	21,86	15,31	14,38	38,11	0,05	300	15,44
52985	FS21211	11	21,72	16,57	13,9	38,02	0,05	300	15,54
52986	FS21212	12	21,73	17,84	14,28	38,09	0,05	300	15,94
52987	FS21213	13	21,73	18,79	13,75	38,07	0,05	300	16,32
52988	FS21214	14	21,85	20,26	14,07	38,17	0,05	300	16,42
52989	FS21215	15	20,77	21,91	14,87	37,9	0,05	300	16,18
52990	FS21216	16	20,77	21,82	14,1	38,06	0,05	300	15,12
52991	FS21217	17	22,04	23,78	15,03	37,85	0,06	324	20,75
52992	FS21218	18	22,89	25,77	14,75	38	0,08	300	24,75
52993	FS21219	19	23,34	25,83	15,44	38,29	0,06	300	19,55
52994	FS21220	20	26,13	27,77	16,2	38,04	0,08	196	16,95
52995	FS21221	21	26,05	27,86	19,97	38,09	0,08	300	24,75
52996	FS21222	22	26,02	29,82	15,67	37,98	0,09	200	18,43
52997	FS21224	24	28,13	31,94	17,33	38,24	0,10	200	21,27
52998	FS21227	27	31,06	35,82	18,23	42,17	0,15	100	15,34
52999	FS21230	30	34,14	39,96	22	43,22	0,19	100	19,76
53001	FS21232	32	36,02	41,69	22,26	44,09	0,21	100	21,67

12-point deep flank sockets 1/2"DR

Cr-V 1/2" 12 DIN

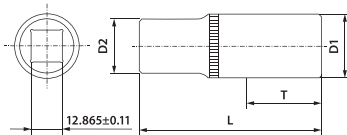

Code	Item No.	Size, mm	D2, mm	D1, mm	T, mm	L, mm	kg	pcs	kg
53002	FS31214	14	20,95	21,7	36,13	77,34	0,11	200	23,31
53003	FS31215	15	20,93	21,81	32,13	76,95	0,11	200	22,85
53004	FS31217	17	22,16	23,79	31,83	77,3	0,12	200	25,65
53005	FS31219	19	24	25,9	36,23	77,13	0,14	160	23,28
53006	FS31222	22	26,01	29,85	33,32	76,96	0,18	120	22,79

MultiProf flank sockets 1/2"DR

Cr-V 1/4" MP DIN

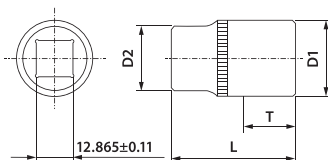

Code	Item No.	Size, mm	D2, mm	D1, mm	T, mm	L, mm	kg	pcs	kg
52941	MP01210	10	21,78	15,47	14,17	38,24	0,05	300	15,37
52942	MP01211	11	21,85	16,54	14,42	38,03	0,05	300	15,54
52943	MP01212	12	21,87	17,95	14,96	38,05	0,05	300	15,41
52944	MP01213	13	21,89	19,12	14,27	38	0,05	300	15,79
52945	MP01214	14	21,87	20,31	14,17	37,92	0,05	300	16,34
52946	MP01215	15	20,66	21,79	15,79	37,91	0,05	300	15,55
52947	MP01216	16	20,99	23,83	14,24	38,07	0,06	324	20,23
52948	MP01217	17	21,97	23,74	13,67	39,97	0,06	324	20
52949	MP01218	18	22,97	25,84	14,11	37,99	0,07	300	22,72
52950	MP01219	19	22,96	25,89	16,89	37,98	0,06	300	18,61
52951	MP01220	20	26,04	27,85	18,54	38,09	0,08	196	16,21
52952	MP01221	21	26,07	29,86	18,12	38,04	0,09	200	18,94
52953	MP01222	22	26,07	29,84	18,13	38,49	0,08	200	17,42
52954	MP01224	24	26,04	27,85	18,54	38,12	0,10	200	20,15
52955	MP01227	27	31,05	36,03	19,92	42,22	0,14	100	14,79
52956	MP01230	30	33,99	39,79	20,67	43,68	0,18	100	18,75
52957	MP01232	32	36,13	41,81	20,61	43,76	0,20	100	20,61

MultiProf deep flank sockets 1/2"DR



Cr-V 1/4" MP DIN

Code	Item No.	Size, mm	D2, mm	D1, mm	T, mm	L, mm	kg	pcs	kg
52958	MP11214	14	21,7	20,38	30,95	78,22	0,11	200	22,64
52959	MP11215	15	21,06	21,94	31,96	77,34	0,11	200	22,32
52960	MP11217	17	22,06	23,98	31,9	77,15	0,12	200	24,47
52961	MP11219	19	23,95	27,81	35,64	77,11	0,14	160	23,43
52962	MP11222	22	26,15	29,82	28,27	77,2	0,18	120	22,6

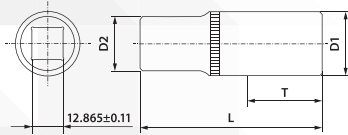

Spark plug sockets

Cr-V 1/2" 6 DIN

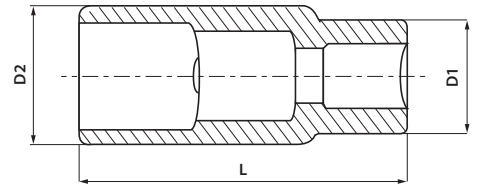

Code	Item No.	Size, mm	D2, mm	D1, mm	L, mm	kg	pcs	kg
52119	SPS1216	16	21.8	21.8	65	0,095	60 / 240	5,72 / 23,3
52120	SPS1221	21	23.6	27.7	65	0,140	40 / 160	5,805 / 23,6

FLANK SOCKETS 1"DR

4-point flank sockets 1"DR for labor save wrench

Cr-V 1" 4 DIN



Code	Item No.	Size, mm
52892	LSWS00117	17
52893	LSWS00119	19
52772	LSWS00121	21
52773	LSWS00122	22

6-point flank sockets 1"DR for labor save wrench

Cr-V 1" 6 DIN

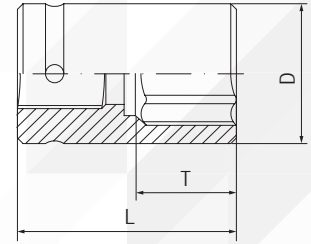

Code	Item No.	Size, mm	D, mm	T, mm	L, mm	kg	pcs	kg
52755	LSWS00124	24	40	25	78	0,5544	50	27,72
52756	LSWS00127	27	44	27	78	0,592	50	29,6
52757	LSWS00130	30	47	30	78	0,6104	50	30,52
52758	LSWS00132	32	48,5	30	78	0,6324	50	31,62
52759	LSWS00133	33	49	30	78	0,648	50	32,4
52760	LSWS00134	34	50	32	78	0,6988	50	34,94
52761	LSWS00136	36	52	32	78	0,7112	50	35,56
52762	LSWS00138	38	55	45	78	0,8128	50	40,64
52763	LSWS00141	41	58	45	78	0,8736	50	43,68
52764	LSWS00146	46	68	45	80	1,1138	32	35,64
52765	LSWS00150	50	72	45	80	1,175	32	37,6
52766	LSWS00152	52	75	45	80	1,3781	32	44,1
52767	LSWS00155	55	78	45	80	1,3238	32	42,36
52768	LSWS00160	60	84	45	80	1,4344	18	25,82
52769	LSWS00165	65	89	48	90	1,9356	18	34,84
52770	LSWS00170	70	94	48	90	2,2889	18	41,2
52771	LSWS00175	75	104	48	90	2,0533	18	36,96

Flank sockets set for labor save wrench

11 pcs.



Cr-V 1" 21-50 mm

Code	Item No.
52774	LSWS11S
<p>Content (11 pieces): 4-point sockets for labor save wrench, 2 pcs: 21, 22 mm; 6-point sockets for labor save wrench, 9 pcs: 27, 30, 32, 33, 36, 38, 41, 46, 50 mm.</p>	

Handles, Universal Joints, Ratchets

Auxiliary tool that is used to transfer torque to the flank socket. It is part of fitting-assembling tools. The range of THORVIK® drives is represented by products that are diverse in scope, design and technology, and includes various joints, extenders, ratchet handles and adapters. Tools of this group will satisfy the needs of the user, both in ease of use and strength and reliability characteristics of products.

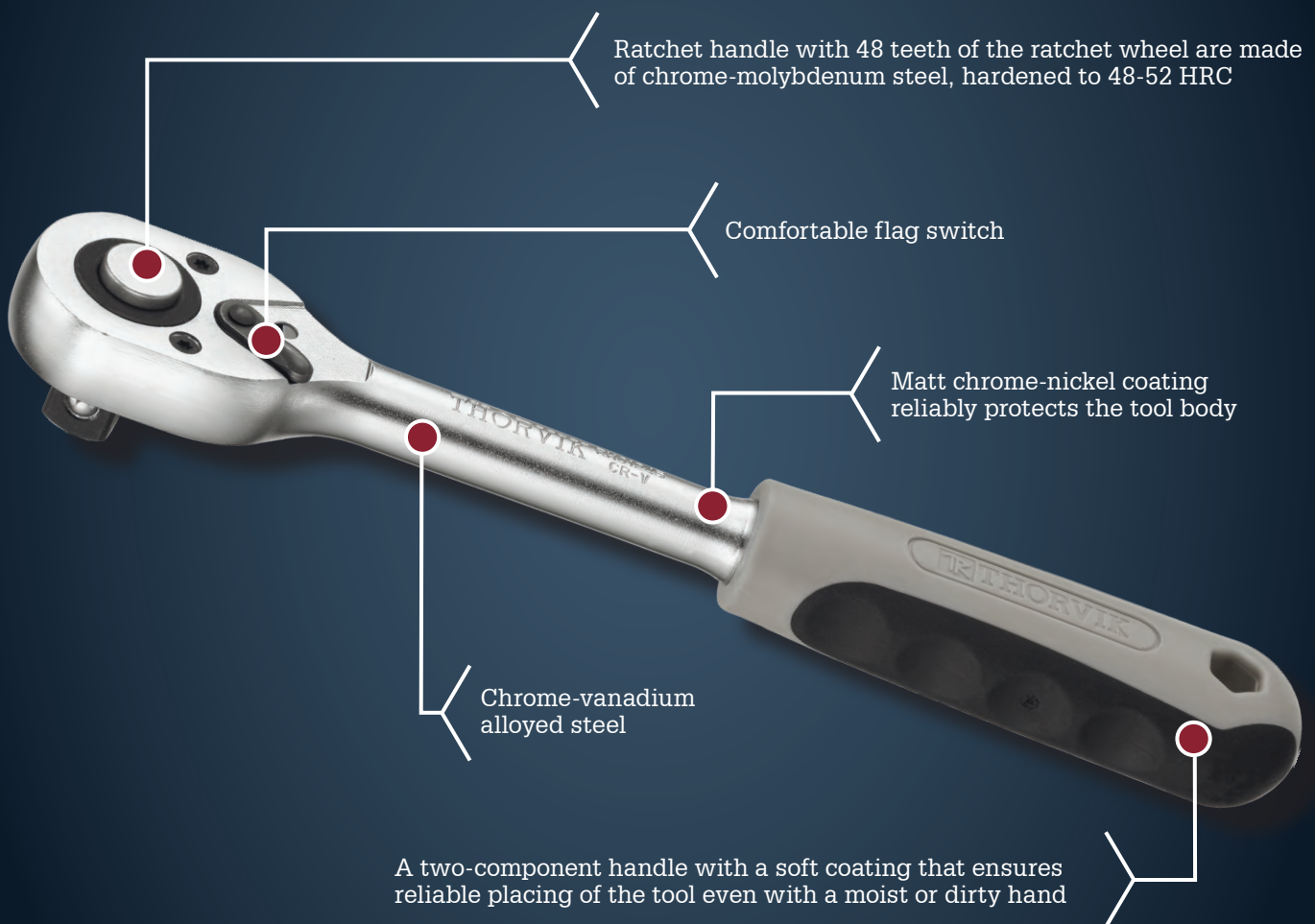

Cr-V Chrome-vanadium steel

1/4" Drive size 1/4" (inch)

1/2" Drive size 1/2" (inch)



Weight of one item



Quantity in the package / shipping box



Packing weight (gross) / shipping box (gross)

HANDLES

Flexible Handle

Cr-V

1/2"



Code	Item No.	DR	L, mm	kg	pcs	kg
52125	FH12380	1/2	380	0,62	10/40	6,275/25,5



Spare parts and repair kits are available for this product:

Repair kit for flexible handle FH12380
Code: 52304; Item No.: FH12380RK

Sliding T bar

Cr-V

1/4" 1/2"

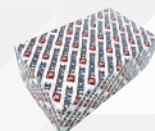

Code	Item No.	DR	L, mm	kg	pcs	kg
52085	TH14011	1/4	110	0,05	100/400	4,57/18,7
52121	TH12250	1/2	250	0,36	10/50	3,62/18,5

Spinner handle

Cr-V

1/4"

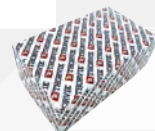

Code	Item No.	DR	L, mm	kg	pcs	kg
52088	SH14150	1/4	150	0,09	50/200	4,4/18,2

RATCHET HANDLES

Ratchet handle

Cr-V

1/4" 1/2"

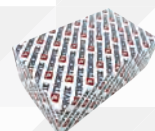

Code	Item No.	DR	L, mm	Number of teeth	kg	pcs	kg
52082	RH01445	1/4	150	48	0,14	10/100	1,405/14
52126	RH01245	1/2	250	48	0,50	10/40	5,095/21,5



Spare parts and repair kits are available for this product:

Repair kit for ratchet handle RH01245RK
Code: 52305; Item No.: RH01245RK

Repair kit for ratchet handle RH01445RK
Code: 52306; Item No.: RH01445RK

EXTENSIONS

Extensions

Cr-V

1/4"

1/2"

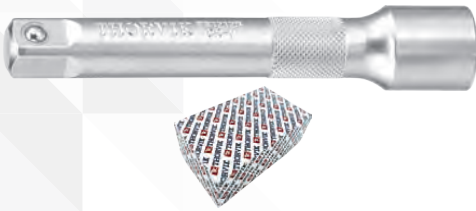

Code	Item No.	DR	L, mm	kg	pcs	kg
52083	EB14050	1/4	50	0,03	100/1000	2,455/25
52084	EB14100	1/4	100	0,05	100/600	4,42/27
52122	EB12125	1/2	125	0,20	20/100	3,935/20
52123	EB12250	1/2	250	0,39	10/50	3,925/19,9

Flexible extension bar

Cr-V

1/4"



Code	Item No.	DR	L, mm	kg	pcs	kg
52087	FEB1415	1/4	150	0,06	50/400	3,04/24,8

UNIVERSAL JOINTS

Universal joints

Cr-V

1/4"

1/2"



Code	Item No.	DR	L, mm	kg	pcs	kg
52086	UJ14000	1/4	35	0,03	100/500	2,5/12,8
52124	UJ12000	1/2	70	0,16	30/120	4,725/19,2







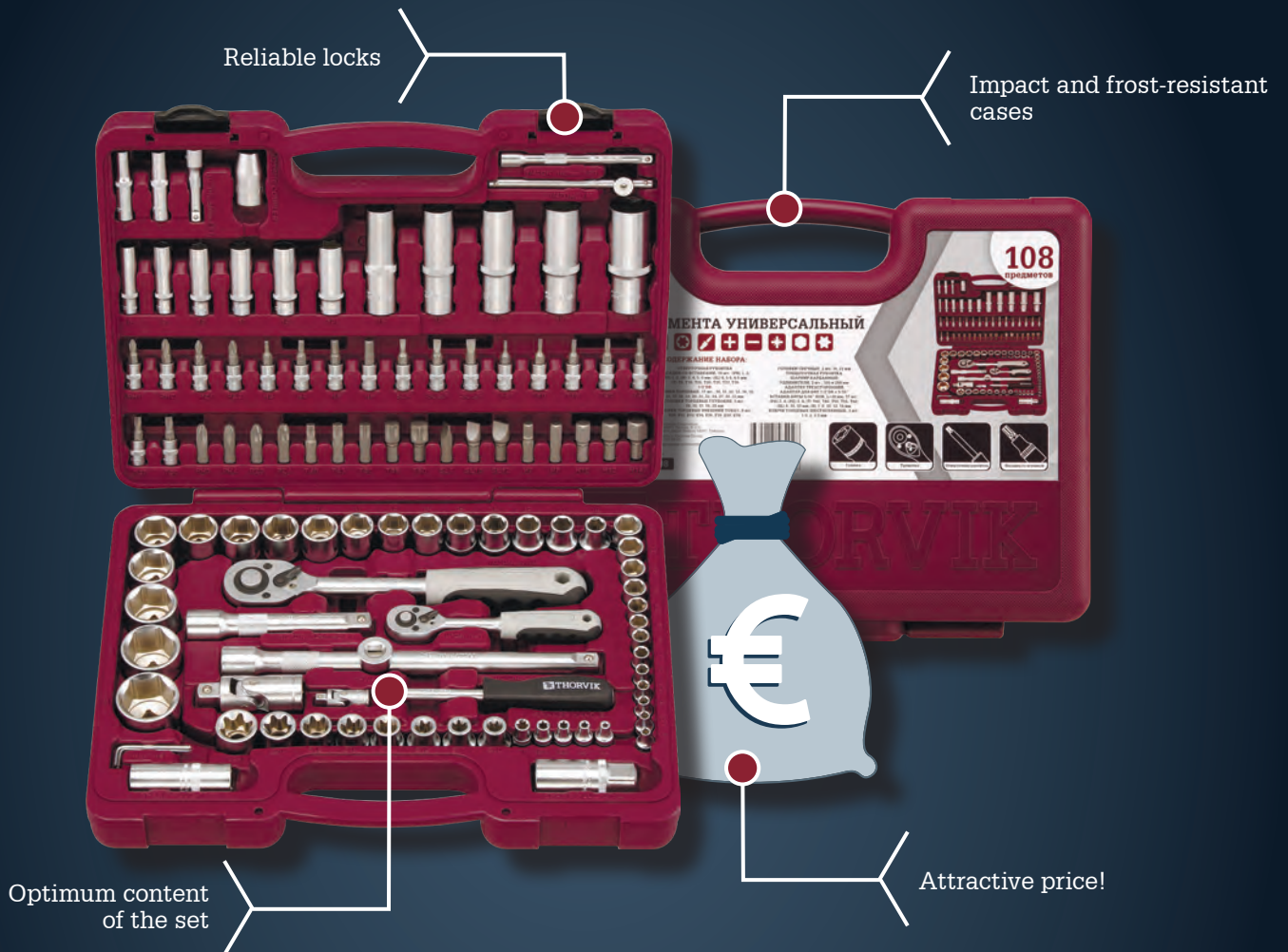









Tool sets

THORVIK® tool sets - high quality of set items, convenient durable storage cases, optimal content to meet the operator's needs for servicing the equipment and to provide with all the necessary workplace during fitting and assembly work.



-  Chrome-vanadium steel
-  Drive size 1/4" (inch)
-  Drive size 3/8" (inch)
-  Drive size 1/2" (inch)
-  Spark plug sockets
-  6-points flank sockets
-  12-point sockets

-  MP (MultiProf) sockets
-  TORX®
-  E-TORX®
-  HEX
-  PHILLIPS®
-  SL Slotted
-  POZIDRIV®

-  Spanners
-  Pliers
-  Adjustable joint pliers
-  Hammer
-  Adjustable wrench
-  Flare nut wrench
-  SPLINE



Weight of one item



Quantity in the package / shipping box



Packing weight (gross) / shipping box (gross)

1/4"DR tool set

38 pcs



Code	Item No.	kg	pcs	kg
52056	UTS0038	1,22	10	12,20
Content (38 pieces):				
Sockets 1/4"DR, 13 pcs		4, 4.5, 5, 5.5, 6, 7, 8, 9, 10, 11, 12, 13, 14 mm		
Deep sockets 1/4"DR, 8 pcs		5, 6, 7, 8, 9, 10, 12, 13 mm		
Bit socket 1/4"DR, 12 pcs		(PH) 1, 2, 3; (H) 3, 4, 5, 6, 7, 8 mm; (SL) 4, 5.5, 7 mm		
Extension 1/4"DR 50 mm		50 mm		
Ratchet handle 1/4"DR		150 mm, 48 teeth		
Universal joint 1/4"DR		35 mm		
Sliding T-bar 1/4"DR		110 mm		

1/4" tool set

57 pcs



Code	Item No.	kg	pcs	kg
52058	UTS0057	1,44	10	14,40
Content (57 pieces):				
Sockets 1/4"DR, 13 pcs		4, 4.5, 5, 5.5, 6, 7, 8, 9, 10, 11, 12, 13, 14 mm		
Deep sockets 1/4"DR, 8 pcs		6, 7, 8, 9, 10, 11, 12, 13 mm		
TORX® sockets 1/4"DR, 5 pcs		E4, E5, E6, E7, E8		
Ratchet handle 1/4"DR		150 mm, 48 teeth		
Sliding T-bar 1/4"DR		110 mm		
Universal joint 1/4"DR		35 mm		
Extension 1/4"DR		75 mm		
Flexible extension 1/4"DR		150 mm		
Spinner handle 1/4"DR		150 mm		
Bit adapter 1/4"DR x 1/4"HDR				
Bits 1/4"HDR l=25 mm, 24 pcs		(PH) 0, 1, 2, 3; (PZ) 0, 1, 2; (H) 3, 4, 5, 6, 7, 8 mm; (T) T8, T9, T10, T15, T20, T25, T27, T30; (SL) 4, 5.5, 7 mm		

1/4" & 1/2"DR Universal tool set

56 pcs



Code	Item No.	kg	pcs	kg
52057	UTS0056	6,00	4	24,00
Content (56 pieces):				
Sockets 1/4"DR, 6 pcs		8, 9, 10, 11, 12, 13 mm		
Spinner handle 1/4"DR		150 mm		
Bit adapter 1/4"DR x 1/4"HDR				
Bits 1/4"HDR, l=25 mm, 14 pcs		(PH) 1, 2, 3; (SL) 3, 4, 5, 6 mm; (TORX®) T10, T15, T20, T25, T27, T30, T40		
Sockets 1/2"DR, 10 pcs		10, 12, 13, 14, 15, 17, 19, 22, 24, 27 mm		
Spark plug sockets 1/2"DR, 2 pcs		16, 21 mm		
Ratchet handle 1/2"DR		250 mm, 48 teeth		
Extension 1/2"DR		125 mm		
Universal joint 1/2"DR		70 mm		
HEX keys, 4 pcs		1.5, 2, 3, 4 mm		
Combination wrenches, 6 pcs		10, 12, 13, 14, 15, 17 mm		
Hammer		0,3 kg		
Pliers		180 mm		
Adjustable joint pliers		250 mm		
Screwdriver, 5 pcs		(PH) 2 x 38 mm, 2 x 100 mm; (PZ) 3 x 200 mm; (SL) 6 x 38 mm, 6 x 100 mm		

1/4" & 1/2"DR Universal tool set

72 pcs



Code	Item No.	kg	pcs	kg
52059	UTS0072	7,70	3	23,10
Content (72 pieces):				
Sockets 1/4"DR, 10 pcs.		4, 5, 6, 7, 8, 9, 10, 11, 12, 13 mm		
Deep sockets 1/4"DR, 5 pcs.		5, 6, 7, 8, 10 mm		
Ratchet handle 1/4"DR		150 mm, 48 teeth		
Universal joint 1/4"DR		35 mm		
Extension 1/4"DR		75 mm		
Spinner handle		150 mm		
Bit adapter 1/4"DR x 1/4"HDR				
Bits 1/4"HDR l=25 mm, 14 pcs.		(PH) 1, 2, 3; (SL) 3, 4, 5, 6 mm; (TORX®) T10, T15, T20, T25, T27, T30, T40		
Sockets 1/2"DR, 13 pcs.		10, 11, 12, 13, 14, 15, 17, 19, 22, 24, 27, 30, 32 mm		
Spark plug sockets 1/2"DR, 2 pcs.		16, 21 mm		
Ratchet handle 1/2"DR		250 mm, 48 teeth		
Extension 1/2"DR		125 mm		
Universal joint 1/2"DR		70 mm		
Hex keys, 3 pcs		1.5, 2, 3, mm		
Combination wrenches, 8 pcs.		10, 11, 12, 13, 14, 15, 17, 19 mm		
Hammer		0,3 kg		
Clamps		250 mm		
Pliers		180 mm		
Adjustable joint pliers		250 mm		
Screwdriver, 5 pcs.		(PH) 2 x 38 mm, 2 x 100 mm; (PZ) 3 x 200 mm; (SL) 6 x 38 mm, 6 x 100 mm		

1/4" & 1/2"DR Universal tool set

77 pcs

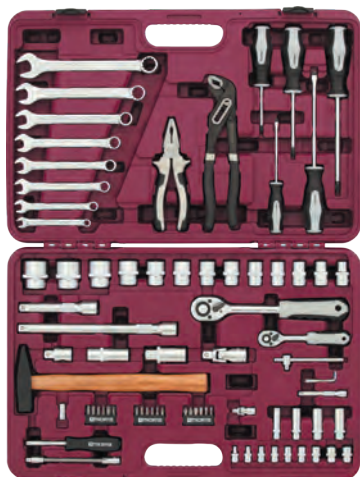

Code	Item No.	kg	pcs	kg
52802	UTS0077	8,00	2	16,80
Content (77 pieces):				
Sockets 1/4"DR, 9 pcs.		4, 5, 6, 7, 8, 9, 10, 11, 12 mm		
Sockets 1/4"DR, 4 pcs.		8, 10, 12, 13 mm		
Ratchet handle 1/4"DR		150 mm, 48 teeth		
Universal joint 1/4"DR		35 mm		
Extension 1/4"DR		75 mm		
Flexible extension 1/4"DR		150 mm		
Spinner handle 1/4"DR		150 mm		
Bit adapter 1/4"DR x 1/4"HDR				
Bits 1/4"HDR l=25 mm, 18 pcs.		(PH) 1, 2, 3; (SL) 3, 4, 5, 6; (H) 3, 4, 5, 6 mm; (T) T10, T15, T20, T25, T27, T30, T40		
Sockets 1/2"DR, 13 pcs.		12, 13, 14, 15, 17, 18, 19, 21, 22, 24, 27, 30, 32 mm		
Spark plug sockets 1/2"DR, 2 pcs.		16, 21 mm		
Ratchet handle 1/2"DR		250 mm, 48 teeth		
Universal joint 1/2"DR		70 mm		
Extension 1/2"DR, 2 pcs.		125, 250 mm		
3-way adapter 1/2"DR				
Hex keys, 3 pcs.		1.5, 2, 3, mm		
Combination wrenches, 8 pcs.		8, 10, 12, 13, 14, 15, 17, 19 mm		
Hammer		0,3 KG		
Pliers		180 mm		
Adjustable joint pliers		250 mm		
Screwdriver, 5 pcs.		(PH) 1 x 75 mm, 2 x 100 mm, 3 x 150 mm; (SL) 4 x 100 mm, 6 x 150 mm		

1/4" & 1/2"DR Universal tool set with 12-point sockets

77
pcs

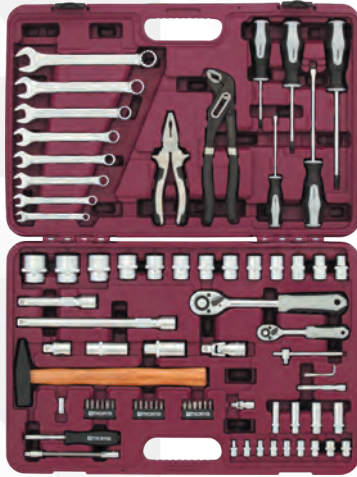

Code	Item No.	kg	pcs	kg
52803	UTS0077/12	8,00	2	16,80
Content (77 pieces):				
12-point sockets 1/4"DR, 9 pcs.		4, 5, 6, 7, 8, 9, 10, 11, 12 mm		
12-point sockets 1/4"DR, 4 pcs.		8, 10, 12, 13 mm		
Ratchet handle 1/4"DR		150 mm, 48 teeth		
Universal joint 1/4"DR		35 mm		
Extension 1/4"DR		75 mm		
Flexible extension 1/4"DR		150 mm		
Spinner handle 1/4"DR		150 mm		
Bit adapter 1/4"DR x 1/4"HDR				
Bits 1/4"HDR l=25 mm, 18 pcs.		(PH) 1, 2, 3; (SL) 3, 4, 5, 6; (H) 3, 4, 5, 6 mm; (T) T10, T15, T20, T25, T27, T30, T40		
12-point sockets 1/2"DR, 13 pcs.		12, 13, 14, 15, 17, 18, 19, 21, 22, 24, 27, 30, 32 mm		
Spark plug sockets 1/2"DR, 2 pcs.		16, 21 mm		
Ratchet handle 1/2"DR		250 mm, 48 teeth		
Universal joint 1/2"DR		70 mm		
Extension 1/2"DR, 2 pcs.		125, 250 mm		
3-way adapter 1/2"DR				
Hex keys, 3 pcs.		1.5, 2, 3, mm		
Combination wrenches, 8 pcs.		8, 10, 12, 13, 14, 15, 17, 19 mm		
Hammer		0,3 KG		
Pliers		180 mm		
Adjustable joint pliers		250 mm		
Screwdriver, 5 pcs.		(PH) 1 x 75 mm, 2 x 100 mm, 3 x 150 mm; (SL) 4 x 100 mm, 6 x 150 mm		

1/4" & 1/2"DR Universal tool set with MultiProf sockets

77
pcs

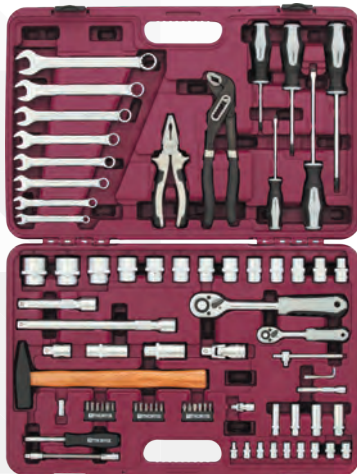

Code	Item No.	kg	pcs	kg
52804	UTS0077MP	8,00	2	16,80
Content (77 pieces):				
MultiProf sockets 1/4"DR, 9 pcs.		4, 5, 6, 7, 8, 9, 10, 11, 12 mm		
MultiProf sockets 1/4"DR, 4 pcs.		8, 10, 12, 13 mm		
Ratchet handle 1/4"DR		150 mm, 48 teeth		
Universal joint 1/4"DR		35 mm		
Extension 1/4"DR		75 mm		
Flexible extension 1/4"DR		150 mm		
Spinner handle 1/4"DR		150 mm		
Bit adapter 1/4"DR x 1/4"HDR				
Bits 1/4"HDR l=25 mm, 18 pcs.		(PH) 1, 2, 3; (SL) 3, 4, 5, 6; (H) 3, 4, 5, 6 mm; (T) T10, T15, T20, T25, T27, T30, T40		
MultiProf sockets 1/2"DR, 13 pcs.		12, 13, 14, 15, 17, 18, 19, 21, 22, 24, 27, 30, 32 mm		
Spark plug sockets 1/2"DR, 2 pcs.		16, 21 mm		
Ratchet handle 1/2"DR		250 mm, 48 teeth		
Universal joint 1/2"DR		70 mm		
Extension 1/2"DR, 2 pcs.		125, 250 mm		
3-way adapter 1/2"DR				
Hex keys, 3 pcs.		1.5, 2, 3, mm		
Combination wrenches, 8 pcs.		8, 10, 12, 13, 14, 15, 17, 19 mm		
Hammer		0,3 KG		
Pliers		180 mm		
Adjustable joint pliers		250 mm		
Screwdriver, 5 pcs.		(PH) 1 x 75 mm, 2 x 100 mm, 3 x 150 mm; (SL) 4 x 100 mm, 6 x 150 mm		

1/4" & 1/2"DR Universal tool set

82 pcs



Code	Item No.	kg	pcs	kg
52060	UTS0082	6,00	4	24,00
Content (82 pieces):				
Sockets 1/4"DR, 13 pcs.		4, 4.5, 5, 5.5, 6, 7, 8, 9, 10, 11, 12, 13, 14 mm		
Ratchet handle 1/4"DR		150 mm, 48 teeth		
Sliding T-bar 1/4"DR		110 mm		
Universal joint 1/4"DR		35 mm		
Extension 1/4"DR, 2 pcs.		50, 100 mm		
Flexible extension 1/4"DR		150 mm		
Spinner handle 1/4"DR		150 mm		
Bit adapter		HDR 1/4" x SDR 1/4"		
Bit socket 1/4"DR, l=25 mm, 17 pcs.		(PH) 1, 2; (PZ) 1, 2; (H) 3, 4, 5, 6 mm; (SL) 4, 5.5, 7 mm; (T) T8, T10, T15, T20, T25, T30		
Sockets 1/2"DR, 12 pcs		14, 15, 16, 17, 18, 19, 21, 22, 24, 27, 30, 32 mm		
Spark plug sockets 1/2"DR, 2 pcs.		16, 21 mm		
Ratchet handle 1/2"DR		250 mm, 48 teeth		
Extension 1/2"DR, 2 pcs.		125, 250 mm		
Universal joint 1/2"DR		70 mm		
3-way adapter 1/2"DR				
Bit adapter 1/2"DR x 5/16"HDR				
Bits 5/16" HDR, l=30 mm, 15 pcs.		(PH) 3, 4; (PZ) 3, 4; (T) T40, T45, T50, T55; (SL) 8, 10, 12 mm; (H) 8, 10, 12, 14 mm		
Combination wrenches, 9 pcs.		8, 10, 11, 12, 13, 14, 17, 19, 22 mm		

1/4" & 1/2"DR Universal tool set with 12-point sockets

82 pcs



Code	Item No.	kg	pcs	kg
52805	UTS0082/12	5,68	4	23,50
Content (82 pieces):				
12-point sockets 1/4"DR, 13 pcs.		4, 4.5, 5, 5.5, 6, 7, 8, 9, 10, 11, 12, 13, 14 mm		
Ratchet handle 1/4"DR		150 mm, 48 teeth		
Sliding T-bar 1/4"DR		110 mm		
Universal joint 1/4"DR		35 mm		
Extension 1/4"DR, 2 pcs.		50, 100 mm		
Flexible extension 1/4"DR		150 mm		
Spinner handle 1/4"DR		150 mm		
Bit adapter		HDR 1/4" x SDR 1/4"		
Bit socket 1/4"DR, l=25 mm, 17 pcs.		(PH) 1, 2; (PZ) 1, 2; (H) 3, 4, 5, 6 mm; (SL) 4, 5.5, 7 mm; (T) T8, T10, T15, T20, T25, T30		
12-point sockets 1/2"DR, 12 pcs.		14, 15, 16, 17, 18, 19, 21, 22, 24, 27, 30, 32 mm		
Spark plug sockets 1/2"DR, 2 pcs.		16, 21 mm		
Ratchet handle 1/2"DR		250 mm, 48 teeth		
Extension 1/2"DR, 2 pcs.		125, 250 mm		
Universal joint 1/2"DR		70 mm		
3-way adapter 1/2"DR				
Bit adapter 1/2"DR x 5/16"HDR				
Bits 5/16" HDR, l=30 mm, 15 pcs.		(PH) 3, 4; (PZ) 3, 4; (T) T40, T45, T50, T55; (SL) 8, 10, 12 mm; (H) 8, 10, 12, 14 mm		
Combination wrenches, 9 pcs.		8, 10, 11, 12, 13, 14, 17, 19, 22 mm		

1/4" & 1/2"DR Universal tool set with MultiProf sockets

82 pcs



Code	Item No.	kg	pcs	kg
52806	UTS0082MP	5,63	4	23,30
Content (82 pieces):				
MultiProf sockets 1/4"DR, 13 pcs.		4, 4.5, 5, 5.5, 6, 7, 8, 9, 10, 11, 12, 13, 14 mm		
Ratchet handle 1/4"DR		150 mm, 48 teeth		
Sliding T-bar 1/4"DR		110 mm		
Universal joint 1/4"DR		35 mm		
Extension 1/4"DR, 2 pcs.		50, 100 mm		
Flexible extension 1/4"DR		150 mm		
Spinner handle 1/4"DR		150 mm		
Bit adapter		HDR 1/4" x SDR 1/4"		
Bit socket 1/4"DR, l=25 mm, 17 pcs.		(PH) 1, 2; (PZ) 1, 2; (H) 3, 4, 5, 6 mm; (SL) 4, 5.5, 7 mm; (T) T8, T10, T15, T20, T25, T30		
MultiProf sockets 1/2"DR, 12 pcs.		14, 15, 16, 17, 18, 19, 21, 22, 24, 27, 30, 32 mm		
Spark plug sockets 1/2"DR, 2 pcs.		16, 21 mm		
Ratchet handle 1/2"DR		250 mm, 48 teeth		
Extension 1/2"DR, 2 pcs.		125, 250 mm		
Universal joint 1/2"DR		70 mm		
3-way adapter 1/2"DR				
Bit adapter 1/2"DR x 5/16"HDR				
Bits 5/16" HDR, l=30 mm, 15 pcs.		(PH) 3, 4; (PZ) 3, 4; (T) T40, T45, T50, T55; (SL) 8, 10, 12 mm; (H) 8, 10, 12, 14 mm		
MultiProf combination wrenches, 9 pcs.		8, 10, 11, 12, 13, 14, 17, 19, 22 mm		

1/4" & 1/2"DR Universal tool set

94 pcs



Code	Item No.	kg	pcs	kg
52061	UTS0094	6,20	4	24,80
Content (94 pieces):				
Sockets 1/4"DR, 13 pcs.		4, 4.5, 5, 5.5, 6, 7, 8, 9, 10, 11, 12, 13, 14 mm		
Deep sockets 1/4"DR, 8 pcs.		6, 7, 8, 9, 10, 11, 12, 13 mm		
Ratchet handle 1/4"DR		150 mm, 48 teeth		
Universal joint 1/4"DR		35 mm		
Sliding T-bar 1/4"DR		110 mm		
Extension 1/4"DR, 2 pcs.		50, 100 mm		
Spinner handle 1/4"DR		150 mm		
Bit socket 1/4"DR, 18 pcs.		(PH) 1, 2; (PZ) 1, 2; (H) 3, 4, 5, 6 mm; (SL) 4, 5.5, 6.5; (T) T8, T10, T15, T20, T25, T27, T30		
Sockets 1/2"DR, 17 pcs.		10, 11, 12, 13, 14, 15, 16, 17, 18, 19, 20, 21, 22, 24, 27, 30, 32 mm		
Deep sockets 1/2"DR, 5 pcs.		14, 15, 17, 19, 22 mm		
Spark plug sockets 1/2"DR, 2 pcs.		16, 21 mm		
Ratchet handle 1/2"DR		250 mm, 48 teeth		
Universal joint 1/2"DR		70 mm		
Extension 1/2"DR, 2 pcs.		125, 250 mm		
3-way adapter 1/2"DR				
Bit adapter 1/2"DR x 5/16"HDR				
Bits 5/16"HDR, l=30 mm, 16 pcs.		(PH) 3, 4; (PZ) 3, 4; (SL) 8, 10, 12 mm; (T) T40, T45, T50, T55; (H) 7, 8, 10, 12, 14 mm		
Hex keys, 3 pcs.		1.5, 2, 2.5 mm		

Universal tool set with 12-point sockets

94 pcs



Code	Item No.	kg	pcs	kg
52807	UTS0094/12	5,98	4	24,70
Content (94 pieces):				
12-point sockets 1/4"DR, 13 pcs.		4, 4.5, 5, 5.5, 6, 7, 8, 9, 10, 11, 12, 13, 14 mm		
12-point sockets 1/4"DR, 8 pcs.		6, 7, 8, 9, 10, 11, 12, 13 mm		
Ratchet handle 1/4"DR		150 mm, 48 teeth		
Universal joint 1/4"DR		35 mm		
Sliding T-bar 1/4"DR		110 mm		
Extension 1/4"DR, 2 pcs .		50, 100 mm		
Spinner handle 1/4"DR		150 mm		
Bit socket 1/4"DR, 18 pcs.		(PH) 1, 2; (PZ) 1, 2; (H) 3, 4, 5, 6 mm; (SL) 4, 5.5, 6.5; (T) T8, T10, T15, T20, T25, T27, T30		
12-point sockets 1/2"DR, 17 pcs.		10, 11, 12, 13, 14, 15, 16, 17, 18, 19, 20, 21, 22, 24, 27, 30, 32 mm		
Deep sockets 1/2"DR, 5 pcs.		14, 15, 17, 19, 22 mm		
Spark plug sockets 1/2"DR, 2 pcs.		16, 21 mm		
Ratchet handle 1/2"DR		250 mm, 48 teeth		
Universal joint 1/2"DR		70 mm		
Extension 1/2"DR, 2 pcs.		125, 250 mm		
3-way adapter 1/2"DR				
Bit adapter 1/2"DR x 5/16"HDR				
Bits 5/16"HDR, l=30 mm, 16 pcs.		(PH) 3, 4; (PZ) 3, 4; (SL) 8, 10, 12 mm; (T) T40, T45, T50, T55; (H) 7, 8, 10, 12, 14 mm		
Hex keys, 3 pcs.		1.5, 2, 2.5 mm		

1/4" & 1/2"DR Universal tool set with MultiProf sockets

94 pcs



Code	Item No.	kg	pcs	kg
52808	UTS0094MP	5,95	4	24,60
Content (94 pieces):				
MultiProf sockets 1/4"DR, 13 pcs.		4, 4.5, 5, 5.5, 6, 7, 8, 9, 10, 11, 12, 13, 14 mm		
MultiProf sockets 1/4"DR, 8 pcs.		6, 7, 8, 9, 10, 11, 12, 13 mm		
Ratchet handle 1/4"DR		150 mm, 48 teeth		
Universal joint 1/4"DR		35 mm		
Sliding T-bar 1/4"DR		110 mm		
Extension 1/4"DR, 2 pcs .		50, 100 mm		
Spinner handle 1/4"DR		150 mm		
Bit socket 1/4"DR, 18 pcs.		(PH) 1, 2; (PZ) 1, 2; (H) 3, 4, 5, 6 mm; (SL) 4, 5.5, 6.5mm; (T) T8, T10, T15, T20, T25, T27, T30		
MultiProf sockets 1/2"DR, 17 pcs.		10, 11, 12, 13, 14, 15, 16, 17, 18, 19, 20, 21, 22, 24, 27, 30, 32 mm		
MultiProf deep sockets 1/2"DR, 5 pcs.		14, 15, 17, 19, 22 mm		
Spark plug sockets 1/2"DR, 2 pcs.		16, 21 mm		
Ratchet handle 1/2"DR		250 mm, 48 teeth		
Universal joint 1/2"DR		70 mm		
Extension 1/2"DR, 2 pcs.		125, 250 mm		
3-way adapter 1/2"DR				
Bit adapter 1/2"DR x 5/16"HDR				
Bits 5/16"HDR, l=30 mm, 16 pcs.		(PH) 3, 4; (PZ) 3, 4; (SL) 8, 10, 12 mm; (T) T40, T45, T50, T55; (H) 7, 8, 10, 12, 14 mm		
Hex keys, 3 pcs.		1.5, 2, 2.5 mm		

1/4" & 1/2"DR Universal tool set

101 pcs

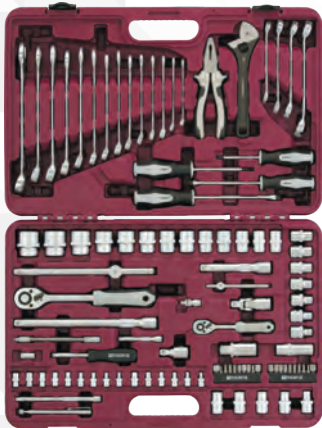

Code	Item No.	kg	pcs	kg
52799	UTS0101	9,87	2	20,53
Content (101 pieces):				
Sockets 1/4"DR, 9 pcs.		4, 4.5, 5, 5.5, 6, 7, 8, 9, 10 mm		
TORX® sockets 1/4"DR, 6 pcs.		E4, E5, E6, E7, E8, E10		
Ratchet handle 1/4"DR		150 mm, 48 teeth		
Sliding T-bar 1/4"DR		110 mm		
Universal joint 1/4"DR		35 mm		
Extension 1/4"DR, 2 pcs.		75, 150 mm		
Flexible extension 1/4"DR		150 mm		
Spinner handle 1/4"DR		150 mm		
Bit adapter 1/4"DR x 1/4"HDR				
Bits 1/4"HDR l=25 mm, 20 pcs.		(H) 3, 4, 5, 6, 7, 8, 10, 12 mm; (T) T15, T20, T25, T27, T30, T40, T45, T50; (XZN) M6, M8, M10, M12		
Sockets 1/2"DR, 20 pcs.		8, 9, 10, 11, 12, 13, 14, 15, 16, 17, 18, 19, 20, 21, 22, 23, 24, 27, 30, 32 mm		
TORX® sockets 1/2"DR, 5 pcs.		E11, E12, E14, E16, E18		
Spark plug sockets 1/2"DR, 2 pcs.		16, 21 mm		
Ratchet handle 1/2"DR		250 mm, 48 teeth		
Universal joint 1/2"DR		70 mm		
Extension 1/2"DR, 2 pcs.		125 и 250 mm		
Extension ball point 1/2"DR		50 mm		
Combination wrenches, 14 pcs.		8, 10, 11, 12, 13, 14, 15, 16, 17, 18, 19, 21, 22, 24 mm		
Flare nut wrenches, 4 pcs.		8x10, 11x13, 12x14, 17x19 mm		
Pliers		180 mm		
Adjustable wrench		200 mm		
Screwdriver, 4 pcs.		(PH) 1x75 mm, 2x100 mm; (SL) 5x125 mm, 6x150 mm		
Magnetic pick up tool				

1/4" & 1/2"DR Universal tool set

108 pcs

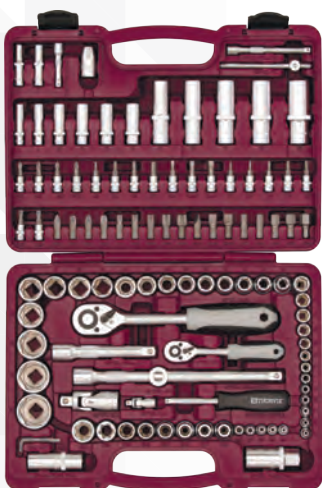

Code	Item No.	kg	pcs	kg
52062	UTS0108	6,82	4	27,30
Content (108 pieces):				
Sockets 1/4"DR, 13 pcs		4, 4.5, 5, 5.5, 6, 7, 8, 9, 10, 11, 12, 13, 14 mm		
Deep sockets 1/4"DR, 8 pcs		6, 7, 8, 9, 10, 11, 12, 13 mm		
TORX® sockets 1/4"DR, 5 pcs		E4, E5, E6, E7, E8		
Ratchet handle 1/4"DR		150 mm, 48 teeth		
Sliding T-bar 1/4"DR		110 mm		
Universal joint 1/4"DR		35 mm		
Extension 1/4"DR, 2 pcs		50, 100 mm		
Spinner handle 1/4"DR		150 mm		
Bit socket 1/4"DR, 18 pcs		(PH) 1, 2; (PZ) 1, 2; (H) 3, 4, 5, 6 mm; (SL) 4, 5.5, 6.5 mm; (T) T8, T10, T15, T20, T25, T27, T30		
Sockets 1/2"DR, 17 pcs		10, 11, 12, 13, 14, 15, 16, 17, 18, 19, 20, 21, 22, 24, 27, 30, 32 mm		
Deep sockets 1/2"DR, 5 pcs		14, 15, 17, 19, 22 mm		
TORX® sockets 1/2"DR, 8 pcs		E10, E11, E12, E14, E16, E18, E20, E24		
Spark plug sockets 1/2"DR, 2 pcs		16, 21 mm		
Ratchet handle 1/2"DR		250 mm, 48 teeth		
Universal joint 1/2"DR		70 mm		
Extension 1/2"DR, 2 pcs		125, 250 mm		
3-way adapter 1/2"DR				
Bit adapter 1/2"DR x 5/16"HDR				
Bits 5/16"HDR l=30 mm, 17 pcs		(PH) 3, 4; (PZ) 3, 4; (T) T40, T45, T50, T55, T60; (SL) 8, 10, 12 mm; (H) 7, 8, 10, 12, 14 mm		
Hex keys, 3 pcs		1.5, 2, 2.5 mm		

1/4" & 1/2"DR Universal tool set with 12-point sockets

108 pcs



Code	Item No.	kg	pcs	kg
52809	UTS108/12	6,50	4	26,80
Content (108 pieces):				
12-point sockets 1/4"DR, 13 pcs.		4, 4.5, 5, 5.5, 6, 7, 8, 9, 10, 11, 12, 13, 14 mm		
12-point deep sockets 1/4"DR, 8 pcs.		6, 7, 8, 9, 10, 11, 12, 13 mm		
TORX® sockets 1/4"DR, 5 pcs.		E4, E5, E6, E7, E8		
Ratchet handle 1/4"DR		150 mm, 48 teeth		
Sliding T-bar 1/4"DR		110 mm		
Universal joint 1/4"DR		35 mm		
Extension 1/4"DR, 2 pcs.		50, 100 mm		
Spinner handle 1/4"DR		150 mm		
Bit socket 1/4"DR, 18 pcs.		(PH) 1, 2; (PZ) 1, 2; (H) 3, 4, 5, 6 mm; (SL) 4, 5.5, 6.5 mm; (T) T8, T10, T15, T20, T25, T27, T30		
12-point sockets 1/2"DR, 17 pcs.		10, 11, 12, 13, 14, 15, 16, 17, 18, 19, 20, 21, 22, 24, 27, 30, 32 mm		
12-point deep sockets 1/2"DR, 5 pcs.		14, 15, 17, 19, 22 mm		
TORX® sockets 1/2"DR, 8 pcs.		E10, E11, E12, E14, E16, E18, E20, E24		
Spark plug sockets 1/2"DR, 2 pcs.		16, 21 mm		
Ratchet handle 1/2"DR		250 mm, 48 teeth		
Universal joint 1/2"DR		70 mm		
Extension 1/2"DR, 2 pcs.		125, 250 mm		
3-way adapter 1/2"DR				
Bit adapter 1/2"DR x 5/16"HDR				
Bits 5/16"HDR l=30 mm, 17 pcs.		(PH) 3, 4; (PZ) 3, 4; (T) T40, T45, T50, T55, T60; (SL) 8, 10, 12 mm; (H) 7, 8, 10, 12, 14 mm		
Hex keys, 3 pcs.		1.5, 2, 2.5 mm		

1/4" & 1/2"DR Universal tool set with MultiProf sockets

108 pcs



Code	Item No.	kg	pcs	kg
52810	UTS0108MP	6,55	4	27,00
Content (108 pieces):				
MultiProf sockets 1/4"DR, 13 pcs.		4, 4.5, 5, 5.5, 6, 7, 8, 9, 10, 11, 12, 13, 14 mm		
MultiProf deep sockets 1/4"DR, 8 pcs.		6, 7, 8, 9, 10, 11, 12, 13 mm		
TORX® sockets 1/4"DR, 5 pcs.		E4, E5, E6, E7, E8		
Ratchet handle 1/4"DR		150 mm, 48 teeth		
Sliding T-bar 1/4"DR		110 mm		
Universal joint 1/4"DR		35 mm		
Extension 1/4"DR, 2 pcs.		50, 100 mm		
Spinner handle 1/4"DR		150 mm		
Bit socket 1/4"DR, 18 pcs.		(PH) 1, 2; (PZ) 1, 2; (H) 3, 4, 5, 6 mm; (SL) 4, 5.5, 6.5 mm; (T) T8, T10, T15, T20, T25, T27, T30		
MultiProf sockets 1/2"DR, 17 pcs.		10, 11, 12, 13, 14, 15, 16, 17, 18, 19, 20, 21, 22, 24, 27, 30, 32 mm		
MultiProf deep sockets 1/2"DR, 5 pcs.		14, 15, 17, 19, 22 mm		
TORX® sockets 1/2"DR, 8 pcs.		E10, E11, E12, E14, E16, E18, E20, E24		
Spark plug sockets 1/2"DR, 2 pcs.		16, 21 mm		
Ratchet handle 1/2"DR		250 mm, 48 teeth		
Universal joint 1/2"DR		70 mm		
Extension 1/2"DR, 2 pcs.		125, 250 mm		
3-way adapter 1/2"DR				
Bit adapter 1/2"DR x 5/16"HDR				
Bits 5/16"HDR l=30 mm, 17 pcs.		(PH) 3, 4; (PZ) 3, 4; (T) T40, T45, T50, T55, T60; (SL) 8, 10, 12 mm; (H) 7, 8, 10, 12, 14 mm		
Hex keys, 3 pcs.		1.5, 2, 2.5 mm		

1/4" & 1/2"DR Universal tool set

127 pcs



Code	Item No.	kg	pcs	kg
52800	UTS0127	15,67	1	16,44
Content (127 pieces):				
Sockets 1/4"DR, 12 pcs.		4, 4.5, 5, 5.5, 6, 7, 8, 9, 10, 11, 12, 13 mm		
Deep sockets 1/4"DR, 5 pcs.		7, 8, 10, 12, 13 mm		
TORX® sockets 1/4"DR, 5 pcs.		E4, E5, E6, E7, E8		
Ratchet handle 1/4"DR		150 mm, 48 teeth		
Sliding T-bar 1/4"DR		110 mm		
Universal joint 1/4"DR		35 mm		
Extension 1/4"DR		75 mm		
Extension ball point 1/4"DR, 2 pcs.		50, 150 mm		
Flexible extension 1/4"DR		150 mm		
Sockets 1/2"DR, 18 pcs.		8, 9, 10, 11, 12, 13, 14, 15, 16, 17, 18, 19, 21, 22, 24, 27, 30, 32 mm		
Deep sockets 1/2"DR, 7 pcs.		10, 12, 13, 14, 15, 17, 19 mm		
TORX® sockets 1/2"DR, 8 pcs.		E10, E12, E14, E16, E18, E20, E22, E24		
Spark plug sockets 1/2"DR, 2 pcs.		16, 21 mm		
Ratchet handle 1/2"DR		250 mm, 48 teeth		
Universal joint 1/2"DR		70 mm		
Extension 1/2"DR, 2 pcs.		125 и 250 mm		
Sliding T-bar 1/2"DR		250 mm		
Flexible handle 1/2"DR		380 mm		
Extension ball point 1/2"DR, 2 pcs.		125, 250 mm		
Extension ball point 1/2"DR		50 mm		
Combination wrenches, 19 pcs.		6, 7, 8, 9, 10, 11, 12, 13, 14, 15, 16, 17, 19, 21, 22, 24, 27, 30, 32 mm		
Flare nut wrenches, 5 pcs.		8x10, 9x11, 12x13, 14x17, 17x19 mm		
Hex keys set, 9 pcs.		1.5, 2, 2.5, 3, 4, 5, 6, 8, 10 mm		
TORX® Key set 7 pcs		T10, T15, T20, T25, T27, T30, T40		
Chisel & punch set, 5 pcs.				
Hammer		0,5 KG		
Pliers		180 mm		
Diagonal cutting pliers		160 mm		
Adjustable joint pliers		250 mm		
Screwdriver, 6 pcs.		(PH) 1x75 mm, 2x38 mm, 2x100 mm; (SL) 5x38 mm, 5x75 mm, 6x100 mm		
Magnetic pick up tool				



1/4" & 1/2"DR Universal tool set

128 pcs

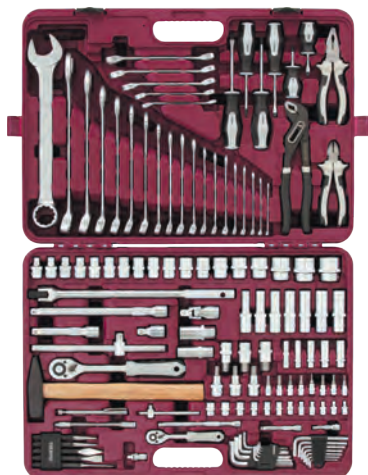

Code	Item No.	kg	pcs	kg
52801	UTS0128	15,77	1	16,54
Content (128 pieces):				
Sockets 1/4"DR, 12 pcs.		4, 4.5, 5, 5.5, 6, 7, 8, 9, 10, 11, 12, 13 mm		
Deep sockets 1/4"DR, 5 pcs.		7, 8, 10, 12, 13 mm		
Ratchet handle 1/4"DR		150 mm, 48 teeth		
Sliding T-bar 1/4"DR		110 mm		
Universal joint 1/4"DR		35 mm		
Extension 1/4"DR		75 mm		
Extension ball point 1/4"DR, 2 pcs.		50, 150 mm		
Flexible extension 1/4"DR		150 mm		
Bit socket 1/4"DR, 8 pcs.		(H) 4, 5, 6; (T) T10, T15, T20, T25, T27		
Sockets 1/2"DR, 18 pcs.		8, 9, 10, 11, 12, 13, 14, 15, 16, 17, 18, 19, 21, 22, 24, 27, 30, 32 mm		
Deep sockets 1/2"DR, 7 pcs.		10, 12, 13, 14, 15, 17, 19 mm		
Spark plug sockets 1/2"DR, 2 pcs.		16, 21 mm		
Ratchet handle 1/2"DR		250 mm, 48 teeth		
Universal joint 1/2"DR		70 mm		
Extension 1/2"DR, 2 pcs.		125, 250 mm		
Sliding T-bar 1/2"DR		250 mm		
Flexible handle 1/2"DR		380 mm		
Extension ball point 1/2"DR, 2 pcs.		125, 250 mm		
Extension ball point 1/2"DR		50 mm		
Bit socket 1/2"DR, 6 pcs.		(H) 7, 8, 10, 12, 14, 17		
Combination wrenches, 19 pcs.		6, 7, 8, 9, 10, 11, 12, 13, 14, 15, 16, 17, 19, 21, 22, 24, 27, 30, 32 mm		
Flare nut wrenches, 5 pcs.		8x10, 9x11, 12x13, 14x17, 17x19 mm		
Hex keys set, 9 pcs.		1.5, 2, 2.5, 3, 4, 5, 6, 8, 10 mm		
Набор ключей торцевых TORX®, 7 пр.		T10, T15, T20, T25, T27, T30, T40		
Chisel & punch set, 5 pcs.				
Hammer		0,5 KG		
Pliers		180 mm		
Diagonal cutting pliers		160 mm		
Adjustable joint pliers		250 mm		
Screwdriver, 6 pcs.		(PH) 1x75 mm, 2x38 mm, 2x100 mm; (SL) 5x38 mm, 5x75 mm, 6x100 mm		
Magnetic pick up tool				



1/4", 3/8" & 1/2"DR Universal tool set

142 pcs

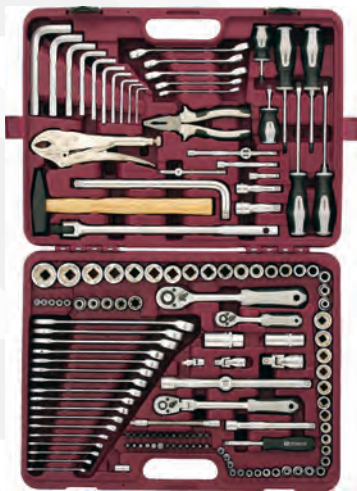

Code	Item No.	kg	pcs	kg
52063	UTS0142	14,00	2	28,00
Content (142 pieces):				
Sockets 1/4"DR, 9 pcs		4, 4.5, 5, 5.5, 6, 7, 8, 9, 10 mm		
TORX® sockets 1/4"DR, 5 pcs		E4, E5, E6, E7, E8		
Ratchet handle 1/4"DR		150 mm, 48 teeth		
Sliding T-bar 1/4"DR		110 mm		
Universal joint 1/4"DR		35 mm		
Extension 1/4"DR, 3 pcs		50, 100, 150 mm		
Flexible extension 1/4"DR		150 mm		
Spinner handle 1/4"DR		150 mm		
Bit adapter 1/4"DR x 1/4"HDR				
Bits 1/4"HDR l=25 mm, 26 pcs		(PH) 0, 1, 2, 3; (PZ) 0, 1, 2, 3; (SL) 4, 5.5, 7; (H) 2, 3, 4, 5, 6, 7, 8, 10 mm; (T) T10, T15, T20, T25, T27, T30, T40		
Sockets 12-points 3/8"DR, 15 pcs		6, 7, 8, 9, 10, 11, 12, 13, 14, 15, 17, 18, 19, 21, 22 mm		
Flexible ratchet handle 3/8"DR		250 mm, 48 teeth		
Extension 3/8"DR, 2 pcs		75, 150 mm		
Universal joint 3/8"DR		50 mm		
3-way adapter 3/8"DR				
Sockets 1/2"DR, 19 pcs		8, 10, 12, 13, 14, 15, 16, 17, 18, 19, 20, 21, 22, 23, 24, 25, 27, 30, 32 mm		
TORX® sockets 1/2"DR, 5 pcs		E10, E12, E14, E16, E20		
Spark plug sockets 1/2"DR, 2 pcs		16, 21 mm		
Ratchet handle 1/2"DR		250 mm, 48 teeth		
Flexible handle 1/2"DR		375 mm		
L-handle 1/2"DR		250 mm		
Extension 1/2"DR, 2 pcs		75, 250 mm		
Universal joint 1/2"DR		70 mm		
3-way adapter 1/2"DR				
Combination wrenches, 17 pcs		6, 7, 8, 9, 10, 11, 12, 13, 14, 15, 16, 17, 18, 19, 21, 22, 24 mm		
Flare nut wrench, 5 pcs		8x10, 10x12, 11x13, 12x14, 17x19 mm		
Hex keys, 10 pcs		2.5, 3, 4, 5, 6, 7, 8, 10, 12, 14 mm		
Screwdriver, 6 pcs		(PH) 2x38 mm, 2x100 mm, 2x100 mm (impact); (SL) 6x38 mm, 6x150 mm, 6x150 mm (impact)		
Hammer		0,3 kg		
Pliers		180 mm		
Clamps		250 mm		

Plastic cases



Code	Item No.	Name
52491	UTS0038BMC	Plastic case for UTS0038
52492	UTS0056BMC	Plastic case for UTS0056
52493	UTS0057BMC	Plastic case for UTS0057
52494	UTS0072BMC	Plastic case for UTS0072
52495	UTS0082BMC	Plastic case for UTS0082
52496	UTS0094BMC	Plastic case for UTS0094
52497	UTS0108BMC	Plastic case for UTS0108
52498	UTS0142BMC	Plastic case for UTS0142

Locker for plastic case Thorvik



Code	Item No.	Name
52499	UTS001	Locker for plastic case THORVIK









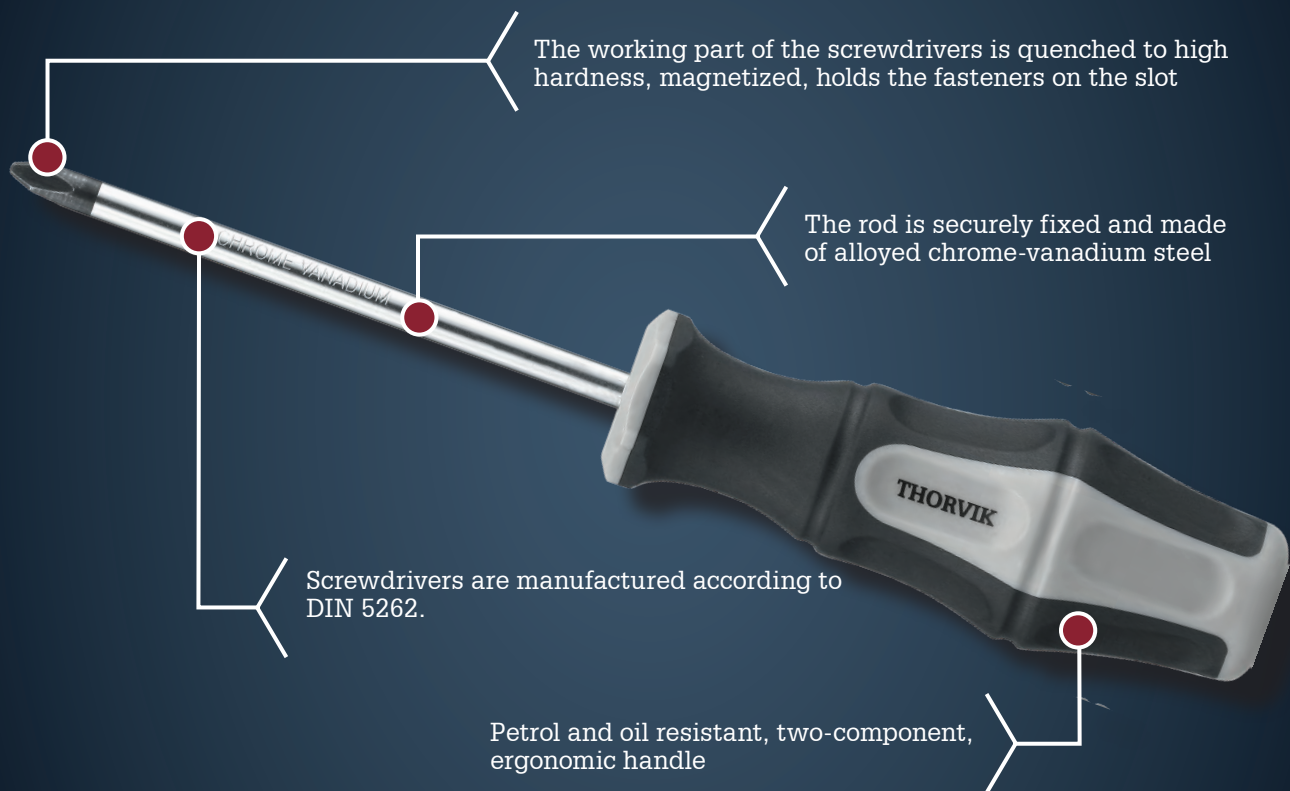



Screwdrivers

THORVIK® screwdrivers are manufactured in accordance with the requirements of DIN 5262 standard. Products are completed with high-quality rods made of chrome-vanadium steel. Magnetized working edge of the screwdrivers are able to hold the fasteners, which very often helps in hard working areas. Ergonomic two-component handles are comfortable. We offer several types of THORVIK® screwdrivers that are used to work with threaded fasteners with internal working profiles: Slot, Phillips®, Pozidriv®,

By design, the screwdrivers can be divided into tools:

1. With concealed installation of the rod in the handle.
2. Screwdrivers with go-thru installation of the rod, which having a steel back plate and a sixsided power amplifier.
3. Insulated screwdrivers.



	SL Slotted		TORX® tamperproof		Complies with the law on safety of equipment and products
	PHILLIPS®		Chrome-vanadium steel		IEC (IEC) 60900 insulation is applicable up to 1000 V
	POZIDRIV®		Magnetized		According to DIN standart
	HEX		Impact tools		
	TORX®		Tested according to VDE		

	Weight of one item		Quantity in the package / shipping box		Packing weight (gross) / shipping box (gross)
---	--------------------	---	--	---	---

SCREWDRIVERS AND SETS OF THEM

Slotted screwdrivers

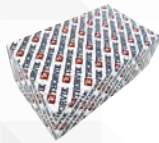
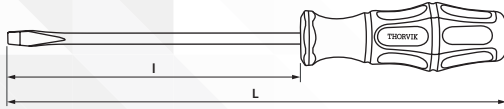

Code	Item No.	mm	mm	l, mm	L, mm	kg	pcs	kg
52130	SDL3075	3	0.5	75	157	0,03	12/240	8
52131	SDL3100	3	0.5	100	182	0,03	12/240	9
52132	SDL3150	3	0.5	150	232	0,04	12/240	9
52133	SDL4100	4	0.8	100	182	0,04	12/240	10
52144	SDL5038	5	1.2	38	98	0,04	12/240	12
52134	SDL5075	5	1.0	75	172	0,06	12/240	15
52135	SDL5100	5	1.0	100	197	0,06	12/240	16
52136	SDL5125	5	1.0	125	222	0,07	12/240	17
52137	SDL5150	5	1.0	150	247	0,07	12/240	17
52138	SDL6100	6	1.2	100	206	0,09	12/120	11
52139	SDL6125	6	1.2	125	231	0,09	12/120	12
52140	SDL6150	6	1.2	150	256	0,10	12/120	13
52141	SDL6200	6	1.2	200	306	0,11	12/96	11
52142	SDL8150	8	1.6	150	264	0,14	6/96	15
52143	SDL8200	8	1.6	200	314	0,16	6/96	17

Go-Thru impact screwdriver

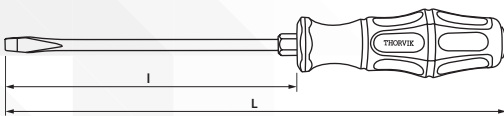

Code	Item No.	mm	mm	l, mm	L, mm	mm	kg	pcs	kg
52163	SDLG575	5	1.0	75	172	8	0,08	12/240	23
52164	SDLG610	6	1.2	100	206	10	0,11	12/120	15
52165	SDLG615	6	1.2	150	256	10	0,12	12/120	17
52166	SDLG815	8	1.6	150	264	12	0,17	6/96	20
52167	SDLG820	8	1.6	200	314	12	0,19	6/96	22

PHILLIPS® screwdriver

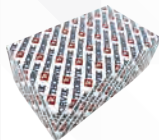
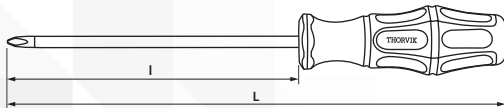

Code	Item No.		l, mm	L, mm	kg	pcs	kg
52145	SDP0075	PH0	75	157	0,03	12/240	8
52146	SDP0100	PH0	100	182	0,03	12/240	9
52147	SDP0150	PH0	150	232	0,04	12/240	9
52148	SDP1075	PH1	75	172	0,06	12/240	15
52149	SDP1100	PH1	100	197	0,06	12/240	16
52150	SDP1125	PH1	125	222	0,07	12/240	17
52151	SDP1150	PH1	150	247	0,07	12/240	17
52158	SDP2038	PH2	38	98	0,04	12/240	12
52152	SDP2100	PH2	100	206	0,09	12/120	11
52153	SDP2125	PH2	125	231	0,09	12/120	12
52154	SDP2150	PH2	150	256	0,10	12/120	13
52155	SDP2200	PH2	200	306	0,11	12/120	14
52156	SDP3150	PH3	150	264	0,14	6/96	15
52157	SDP3200	PH3	200	314	0,16	6/96	17

PHILLIPS® Go-Thru impact Screwdriver

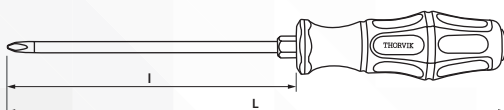

Code	Item No.		l, mm	L, mm	mm	kg	pcs	kg
52168	SDPG175	PH1	75	172	8	0,08	12/240	23
52169	SDPG210	PH2	100	206	10	0,11	12/120	16
52170	SDPG215	PH2	150	256	10	0,12	12/120	17
52171	SDPG220	PH2	200	306	10	0,13	12/120	18

Screwdriver sets

Screwdriver set, 6 pcs.



Code	Item No.	kg	pcs	kg
52292	SDS06CP	0,62	20	13,5
Content: SL5x75 mm, SL6x100 mm, SL8x150 mm, PH0x75 mm, PH1x75 mm, PH2x100 mm				

Screwdriver set, 7 pcs.



Code	Item No.	kg	pcs	kg
52293	SDS07CO	0,62	12	8,4
Content: SL3x75 mm, SL5.5x100 mm, SL6.5x125 mm, SL8x150 mm, PH0x75 mm, PH1x100 mm, PH2x125 mm				

Screwdriver set, 6 pcs. on a plastic holder



Code	Item No.	kg	pcs	kg
52290	SDS06BC	0,53	24	13,7
Content: SL5x75 mm, SL6x38 mm, SL6x100 mm, PH1x75 mm, PH2x38 mm, PH2x100 mm				

Screwdriver set, 6 pcs. on an installable plastic holder



Code	Item No.	kg	pcs	kg
52291	SDS06BH	0,55	24	14,1
Content: SL3x75 mm, SL5x100 mm, SL6x125 mm, PH0x75 mm, PH1x100 mm, PH2x125 mm				

Go-thru impact screwdriver set, 7 pcs.



Code	Item No.	kg	pcs	kg
52288	SDGS7CP	0,79	12	10,6
Content: SL4x100 mm, SL5.5x100 mm, SL6.5x125 mm, SL8x150 mm, PH0x60 mm, PH1x80 mm, PH2x100 mm				

Pozidriv® screwdrivers

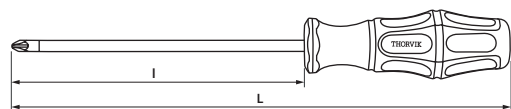

Code	Item No.	+	l, mm	L, mm	kg	pcs	kg
52159	SDZ0075	PZ0	75	157	0,03	12/240	8
52160	SDZ1100	PZ1	100	197	0,06	12/240	16
52161	SDZ2100	PZ2	100	206	0,09	12/120	11
52162	SDZ3150	PZ3	150	264	0,14	6/96	15

INSULATED SCREWDRIVERS AND SETS OF THEM

Insulated slotted screwdriver

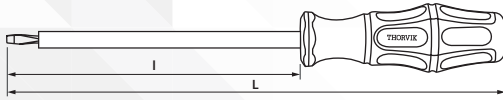

Code	Item No.	mm	mm	l, mm	L, mm	kg	pcs	kg
52172	SDLI275	2,5	0,4	75	165	0,05	12/240	13
52173	SDLI410	4	0,8	100	188	0,06	12/240	15
52174	SDLI512	5,5	1,0	125	225	0,08	12/240	19
52175	SDLI615	6,5	1,2	150	260	0,08	12/120	11
52176	SDLI817	8	1,6	175	295	0,09	6/96	9

Insulated PHILLIPS® screwdriver

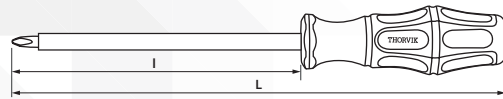

Code	Item No.		l, mm	L, mm	kg	pcs	kg
52177	SDPI060	PH0	60	148	0,05	12/240	13
52178	SDPI180	PH1	80	180	0,06	12/240	15
52179	SDPI210	PH2	100	210	0,07	12/120	10
52180	SDPI315	PH3	150	270	0,09	6/96	9

Insulated screwdriver set

6 pcs



Code	Item No.	kg	pcs	kg
52289	SDIS6CP	0,52	24	13,6

Content: SL4x100 mm, SL5.5x125 mm, PH1x80 mm, PH2x100 mm, PH3x150 mm, Electric tester

POCKET SCREWDRIVER 4 IN 1

Pocket screwdriver 4 in 1

4 pcs



Code	Item No.	kg	pcs	kg
52287	PPSDS41	0,035	288	11,1

Content: Case with two protective caps, double-sided rods, 2 pcs. PH0/SL3, PH1/SL4

HEX KEYS AND SETS OF THEM

Hex keys short

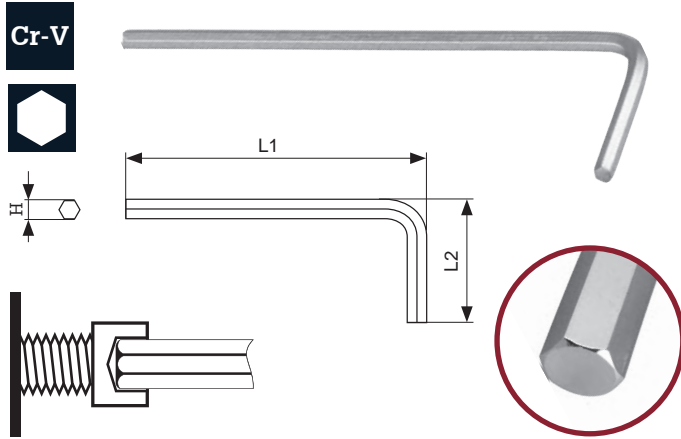

Code	Item No.	L1, mm	L2, mm	H	KG
53023	HKS15	46,5	15,5	H1,5	0,001
53024	HKS20	52	18	H2	0,0018
53025	HKS25	58,5	20,5	H2,5	0,003
53026	HKS30	66	23	H3	0,005
53027	HKS40	74	28	H4	0,01
53028	HKS50	85	33	H5	0,018
53029	HKS60	96	38	H6	0,029
53030	HKS70	102	41	H7	0,043
53031	HKS80	108	44	H8	0,061
53032	HKS100	122	50	H10	0,107

Hex keys

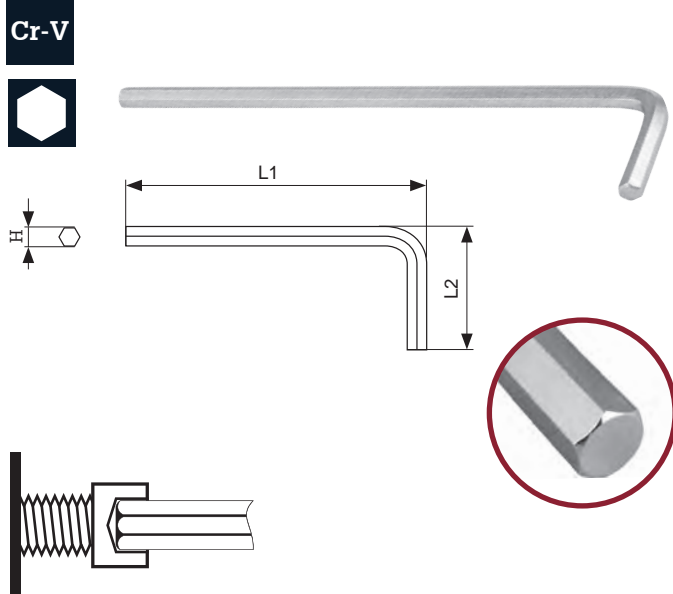

Code	Item No.	L1, mm	L2, mm	H	KG
53035	HK15	69,5	15,5	H1,5	0,002
53036	HK20	77	18	H2	0,004
53037	HK25	86,5	20,5	H2,5	0,005
53038	HK30	98	23	H3	0,006
53039	HK40	109	28	H4	0,015
53040	HK50	125	33	H5	0,025
53041	HK60	141	38	H6	0,040
53042	HK70	149	41	H7	0,06
53043	HK80	158	44	H8	0,080
53044	HK90	167	47	H9	0,11
53045	HK100	178	50	H10	0,140
53046	HK120	194	57	H12	0,245
53047	HK140	214	69	H14	0,375
53048	HK170	249	77	H17	0,615
53049	HK190	295	89	H19	0,855
53050	HK220	322	102	H22	1,350

Hex keys long

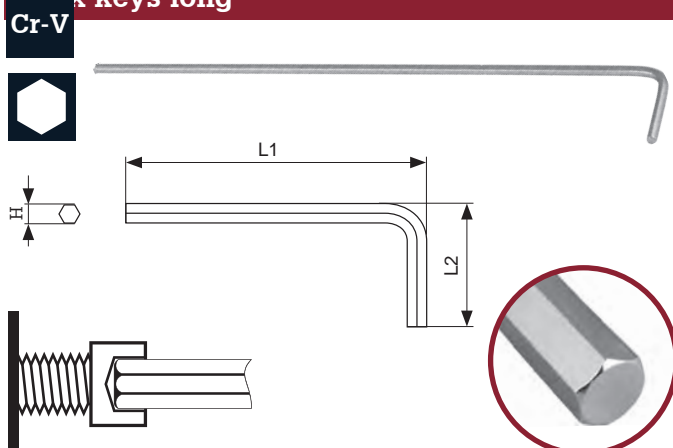

Code	Item No.	L1, mm	L2, mm	H	KG
53053	HKL15	91,5	15,5	H1,5	0,002
53054	HKL20	102	18	H2	0,004
53055	HKL25	114,5	20,5	H2,5	0,006
53056	HKL30	129	23	H3	0,008
53057	HKL40	144	28	H4	0,018
53058	HKL50	163	33	H5	0,032
53059	HKL60	184	38	H6	0,052
53060	HKL70	194	41	H7	0,077
53061	HKL80	206	44	H8	0,102
53062	HKL100	232	50	H10	0,172



Hex keys set

Hex keys set short, H1.5-H10

9 pcs.



Code	Item No.	KG	pcs.	KG
53021	HKS9S	0,25	60	16
Content: H1.5, H2, H2.5, H3, H4, H5, H6, H8, H10 mm				

Hex keys set, H1.5-H10

10 pcs.

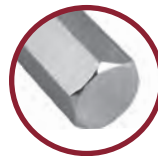

Code	Item No.	KG	pcs.	KG
53022	HKS10S	0,28	60	18
Content: H1.5, H2, H2.5, H3, H4, H5, H6, H7, H8, H10 mm				

Hex keys set, H1.5-H10

9 pcs.



Code	Item No.	KG	pcs.	KG
53033	HK9S	0,33	60	21
Content: H1.5, H2, H2.5, H3, H4, H5, H6, H8, H10 mm				

Hex keys set H1.5-H10

10 pcs.



Code	Item No.	KG	pcs.	KG
53034	HK10S	0,36	60	23
Content: H1.5, H2, H2.5, H3, H4, H5, H6, H7, H8, H10 mm				

Hex keys set long, H1.5-H10

9 pcs.



Code	Item No.	KG	pcs.	KG
53051	HKL9S	0,45	60	28
Content: H1.5, H2, H2.5, H3, H4, H5, H6, H8, H10 mm				

Hex keys set long, H1.5-H10

10 pcs.



Code	Item No.	KG	pcs.	KG
53052	HKL10S	0,5	60	31
Content: H1.5, H2, H2.5, H3, H4, H5, H6, H7, H8, H10 mm				

Hex keys ball point short

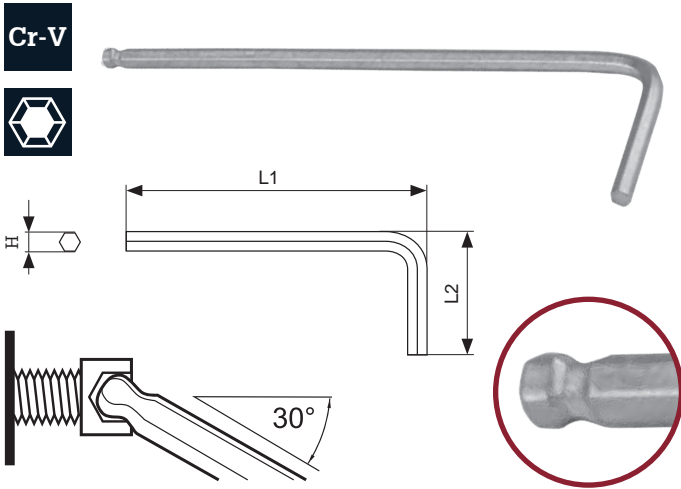

Code	Item No.	L1, mm	L2, mm		
53065	HKSB15	46,5	15,5	H1,5	0,001
53066	HKSB20	52	18	H2	0,0018
53067	HKSB25	58,5	20,5	H2,5	0,003
53068	HKSB30	66	23	H3	0,005
53069	HKSB40	74	28	H4	0,01
53070	HKSB50	85	33	H5	0,018
53071	HKSB60	96	38	H6	0,029
53072	HKSB70	102	41	H7	0,043
53073	HKSB80	108	44	H8	0,061
53074	HKSB100	122	50	H10	0,107

Hex keys ball point

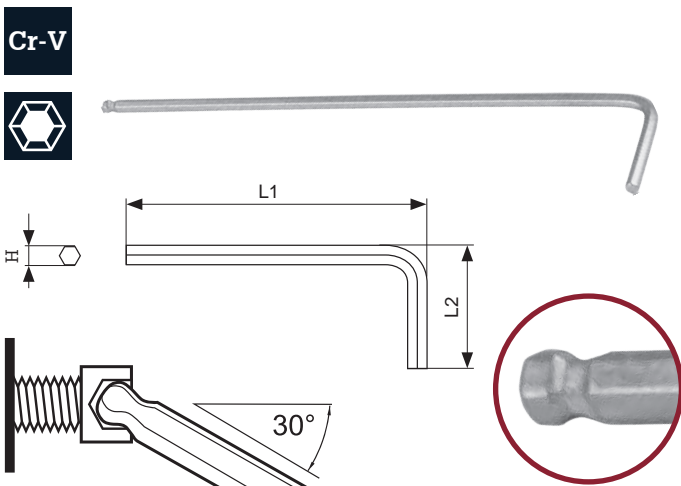

Code	Item No.	L1, mm	L2, mm		
53077	HKB15	69,5	15,5	H1,5	0,002
53078	HKB20	77	18	H2	0,004
53079	HKB25	86,5	20,5	H2,5	0,005
53080	HKB30	98	23	H3	0,006
53081	HKB40	109	28	H4	0,015
53082	HKB50	125	33	H5	0,025
53083	HKB60	141	38	H6	0,040
53084	HKB70	149	41	H7	0,06
53085	HKB80	158	44	H8	0,080
53086	HKB100	178	50	H9	0,14

Hex keys long ball point

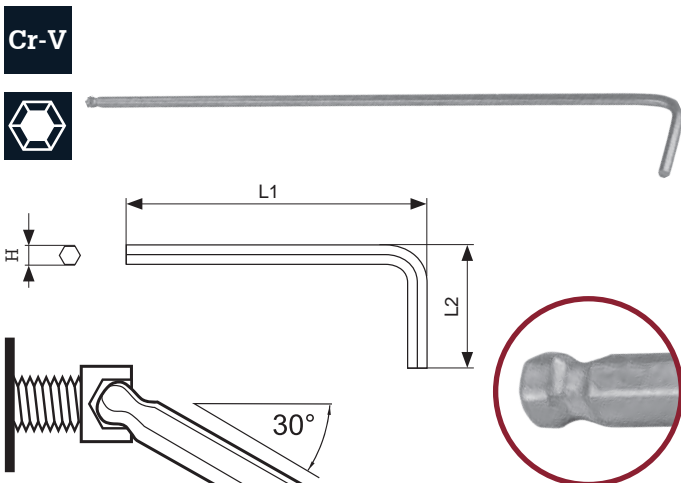

Code	Item No.	L1, mm	L2, mm		
53089	HKLB15	91,5	15,5	H1,5	0,002
53090	HKLB20	102	18	H2	0,004
53091	HKLB25	114,5	20,5	H2,5	0,006
53092	HKLB30	129	23	H3	0,008
53093	HKLB40	144	28	H4	0,018
53094	HKLB50	163	33	H5	0,032
53095	HKLB60	184	38	H6	0,052
53096	HKLB70	194	41	H7	0,077
53097	HKLB80	206	44	H8	0,102
53098	HKLB100	232	50	H10	0,172

Hex keys ball point sets

Hex keys short ball point set, H1.5-H10

9 pcs.



Cr-V

Code	Item No.	KG	pcs.	KG
53063	HKSB9S	0,25	60	16
Content: H1.5, H2, H2.5, H3, H4, H5, H6, H8, H10 mm				

Hex keys short ball point set, H1.5-H10

10 pcs.



Cr-V

Code	Item No.	KG	pcs.	KG
53064	HKSB10S	0,28	60	18
Content: H1.5, H2, H2.5, H3, H4, H5, H6, H7, H8, H10 mm				

Hex keys ball point set, H1.5-H10

9 pcs.



Cr-V

Code	Item No.	KG	pcs.	KG
53075	HKB9S	0,33	60	21
Content: H1.5, H2, H2.5, H3, H4, H5, H6, H8, H10 mm				

Hex keys ball point set, H1.5-H10

10 pcs.



Cr-V

Code	Item No.	KG	pcs.	KG
53076	HKB10S	0,36	60	23
Content: H1.5, H2, H2.5, H3, H4, H5, H6, H7, H8, H10 mm				

Hex keys long ball point set, H1.5-H10

9 pcs.



Cr-V

Code	Item No.	KG	pcs.	KG
53087	HKLB9S	0,45	60	28
Content: H1.5, H2, H2.5, H3, H4, H5, H6, H8, H10 mm				

Hex keys long ball point set, H1.5-H10

10 pcs.



Cr-V

Code	Item No.	KG	pcs.	KG
53088	HKLB10S	0,5	60	31
Content: H1.5, H2, H2.5, H3, H4, H5, H6, H7, H8, H10 mm				

Hex keys long SAE

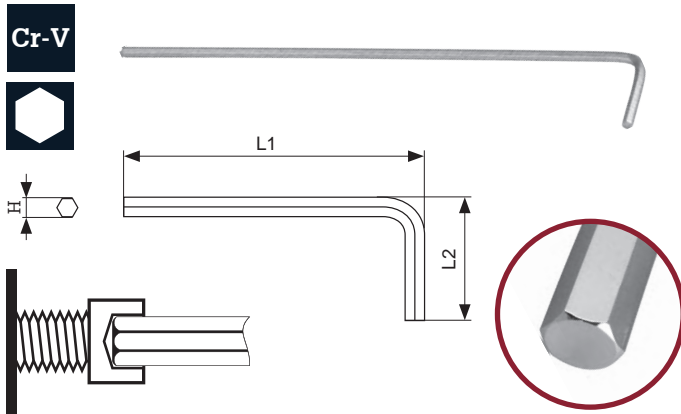

Code	Item No.	L1, mm	L2, mm	H	KG
53100	HKIL116	91,5	15,5	H1/16"	0,002
53101	HKIL564	102	18	H5/64"	0,004
53102	HKIL332	114,5	20,5	H3/32"	0,006
53103	HKIL18	129	23	H1/8"	0,008
53104	HKIL532	144	28	H5/32"	0,018
53105	HKIL316	152,5	30,5	H3/16"	0,032
53106	HKIL732	163,5	34,5	H7/32"	0,0403
53107	HKIL14	184	38	H1/4"	0,0597
53108	HKIL516	211	44	H5/16"	0,108
53109	HKIL38	232	50	H3/8"	0,17

Hex key long SAE set

Hex keys long SAE set, H1/16"-H3/8"



Code	Item No.	KG	pcs.	KG
53099	HKIL10S	0,5	60	31

Content: H1/16", H5/64", H3/32", H1/8", H5/32", H3/16", H7/32", H1/4", H5/16", H3/8"

TORX KEYS AND SETS OF THEM

Torx keys short

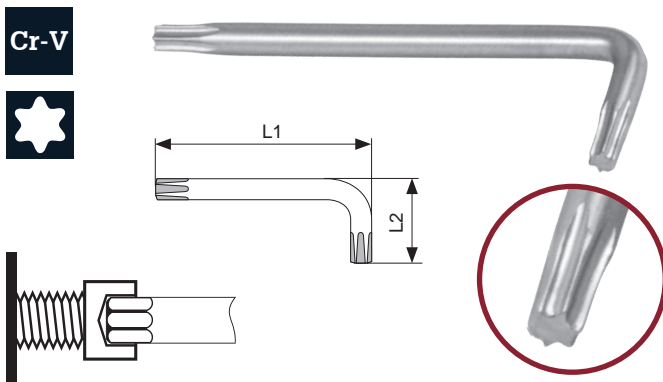

Code	Item No.	L1, mm	L2, mm	H	KG
53111	TKS10	48	17	T10	0,004
53112	TKS15	53,5	19,5	T15	0,004
53113	TKS20	60	22	T20	0,008
53114	TKS25	67,5	24,5	T25	0,012
53115	TKS27	75	29	T27	0,016
53116	TKS30	85,5	33,5	T30	0,020
53117	TKS40	97	39	T40	0,038
53118	TKS45	108	44	T45	0,055
53119	TKS50	121	49	T50	0,076

Torx keys

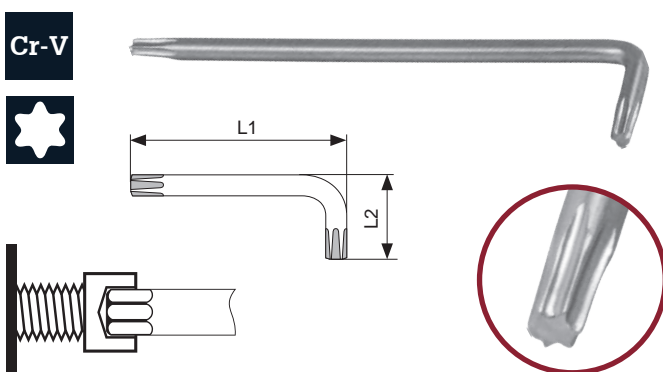

Code	Item No.	L1, mm	L2, mm	H	KG
53121	TK10	71	17	T10	0,005
53122	TK15	78,5	19,5	T15	0,006
53123	TK20	88	22	T20	0,010
53124	TK25	99,5	24,5	T25	0,013
53125	TK27	110	29	T27	0,019
53126	TK30	125,5	33,5	T30	0,026
53127	TK40	142	39	T40	0,048
53128	TK45	158	44	T45	0,073
53129	TK50	177	49	T50	0,102

Torx keys long

Cr-V

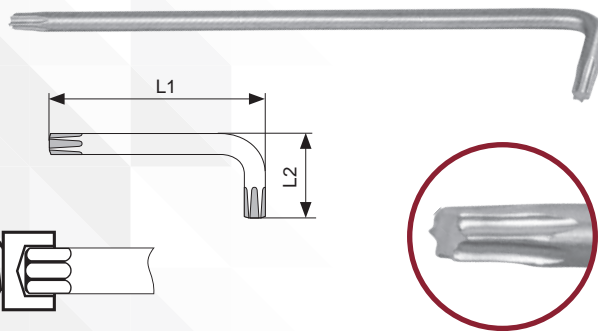

Code	Item No.	L1, mm	L2, mm	H	KG
53131	TKL10	93	17	T10	0,006
53132	TKL15	103,5	19,5	T15	0,007
53133	TKL20	116	22	T20	0,013
53134	TKL25	130,5	24,5	T25	0,018
53135	TKL27	145	29	T27	0,025
53136	TKL30	163,5	33,5	T30	0,036
53137	TKL40	185	39	T40	0,065
53138	TKL45	206	44	T45	0,096
53139	TKL50	231	49	T50	0,133

Torx keys short sets

Torx keys short set, T10-T50

9 pcs.



Code	Item No.	KG	pcs.	KG
53110	TKS9S	0,25	60	16

Content: T10, T15, T20, T25, T27, T30, T40, T45, T50

Torx keys set, T10-T50

10 pcs.



Code	Item No.	KG	pcs.	KG
53120	TK9S	0,33	60	21

Content: T10, T15, T20, T25, T27, T30, T40, T45, T50

Torx key long set, T10-T50

9 pcs.



Cr-V

Code	Item Number	KG	pcs.	KG
53130	TKL9S	0,45	60	28

Content: T10, T15, T20, T25, T27, T30, T40, T45, T50

Torx key short tamper proof

Cr-V

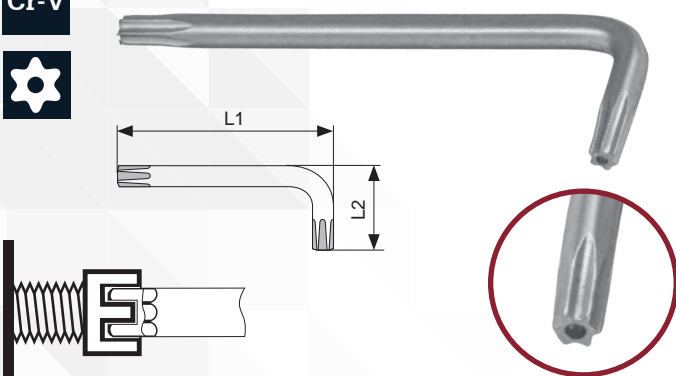

Code	Item No.	L1, mm	L2, mm	H	KG
53141	TTKS10	48	17	T10H	0,004
53142	TTKS15	53,5	19,5	T15H	0,004
53143	TTKS20	60	22	T20H	0,008
53144	TTKS25	67,5	24,5	T25H	0,012
53145	TTKS27	75	29	T27H	0,016
53146	TTKS30	85,5	33,5	T30H	0,020
53147	TTKS40	97	39	T40H	0,038
53148	TTKS45	108	44	T45H	0,055
53149	TTKS50	121	49	T50H	0,076

Torx key short tamper proof

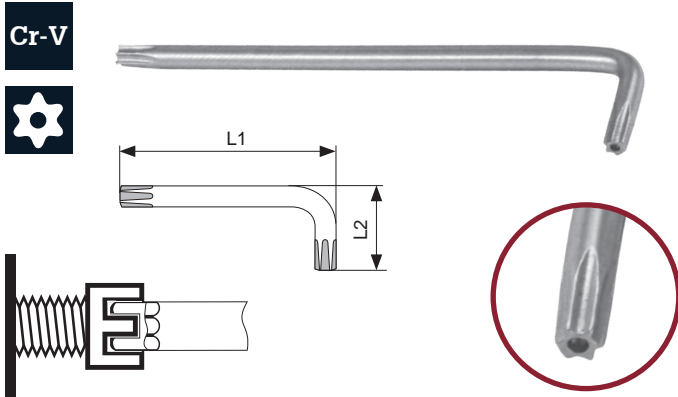

Code	Item No.	L1, mm	L2, mm	Star	KG
53151	TTK10	71	17	T10H	0,005
53152	TTK15	78,5	19,5	T15H	0,006
53153	TTK20	88	22	T20H	0,010
53154	TTK25	99,5	24,5	T25H	0,013
53155	TTK27	110	29	T27H	0,019
53156	TTK30	125,5	33,5	T30H	0,026
53157	TTK40	142	39	T40H	0,048
53158	TTK45	158	44	T45H	0,073
53159	TTK50	177	49	T50H	0,102

Torx key long tamper proof

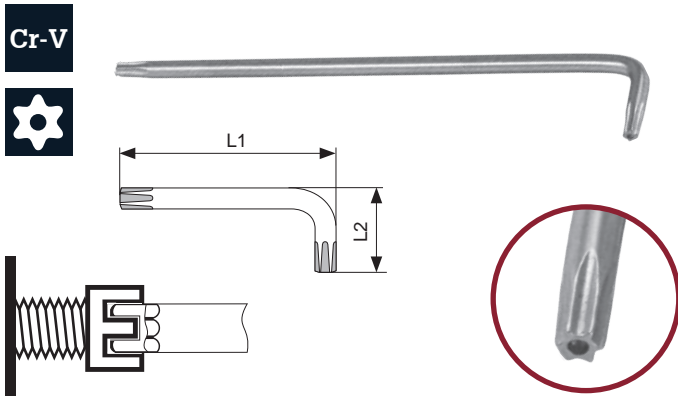

Code	Item No.	L1, mm	L2, mm	Star	KG
53161	TTKL10	93	17	T10H	0,006
53162	TTKL15	103,5	19,5	T15H	0,007
53163	TTKL20	116	22	T20H	0,013
53164	TTKL25	130,5	24,5	T25H	0,018
53165	TTKL27	145	29	T27H	0,025
53166	TTKL30	163,5	33,5	T30H	0,036
53167	TTKL40	185	39	T40H	0,065
53168	TTKL45	206	44	T45H	0,096
53169	TTKL50	231	49	T50H	0,133

Torx keys tamper proof sets

Torx keys short tamper proof set, T10H-T50H

9 pcs.

Cr-V

Code	Item No.	KG	pcs.	KG
53140	TTKS9S	0,25	60	16

Content: T10H, T15H, T20H, T25H, T27H, T30H, T40H, T45H, T50H

Torx keys tamper proof set, T10H-T50H

9 pcs.

Cr-V

Code	Item No.	KG	pcs.	KG
53150	TTK9S	0,33	60	18

Content: T10H, T15H, T20H, T25H, T27H, T30H, T40H, T45H, T50H

Torx keys long tamper proof set, T10H-T50H

9 pcs.

Cr-V









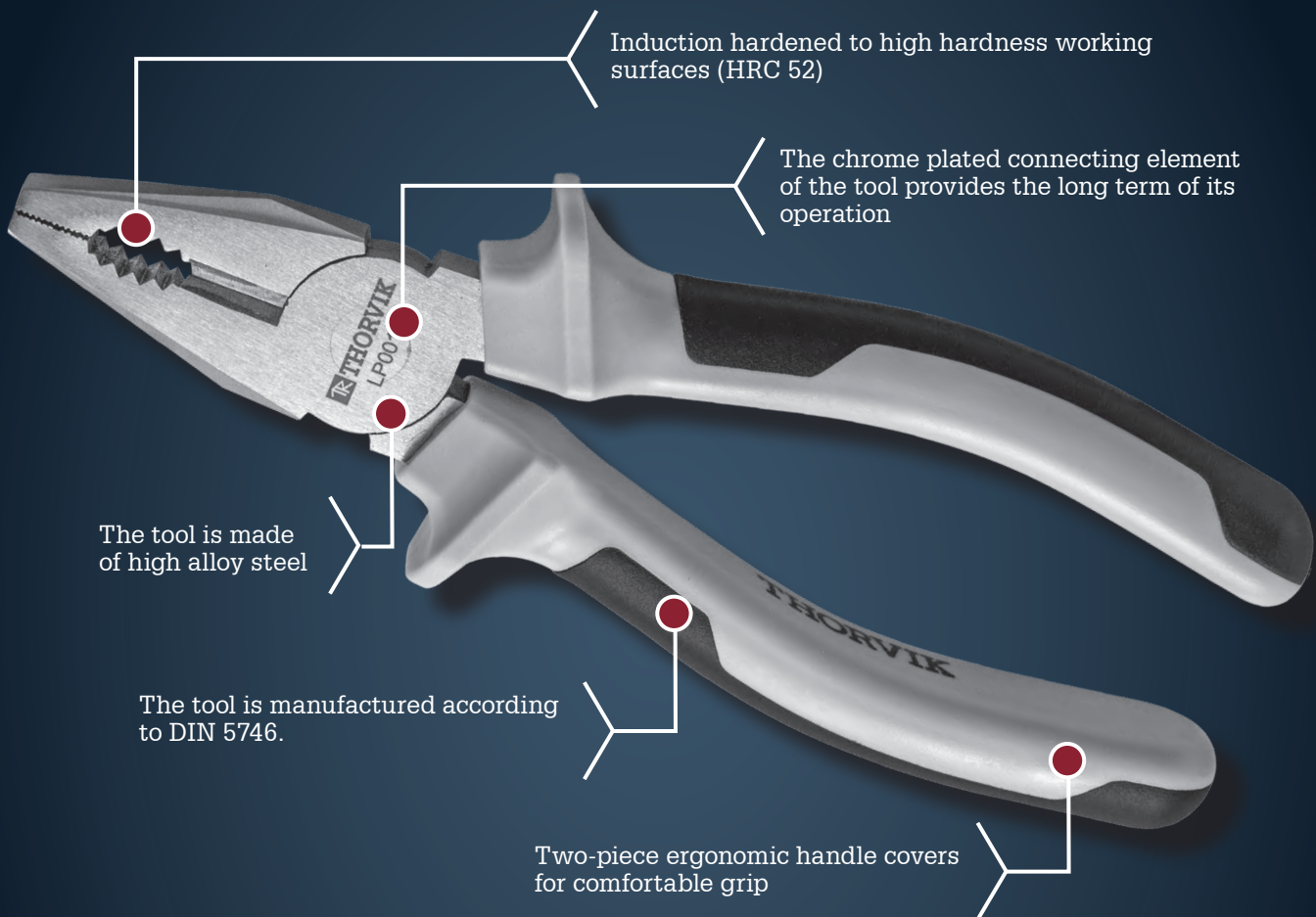





Code	Item No.	KG	pcs.	KG
53160	TTKL9S	0,45	60	21

Content: T10H, T15H, T20H, T25H, T27H, T30H, T40H, T45H, T50H

Pliers

A group of hand tools used for fixing objects, cutting, bending materials. THORVIK® pliers are characterized by high quality. Products are made from alloyed steel, have work surfaces quenched to high hardness and a chrome-plated joint element, which ensures their long service life. The tools are equipped with two-component ergonomic handles, meet all modern technical standards.



	Combination pliers		Water pump pliers		Internal type of locking ring
	Long nose pliers		Notches on work surfaces		45° Bend angle of working surfaces
	Diagonal cutting pliers		Cutting edge profile		90° Angle of bend of working surfaces
	Nippers		External type of locking ring		DIN According to DIN standart
	Flat nose		Oval-shaped work surfaces		



Weight of one item



Quantity in the package / shipping box



Packing weight (gross) / shipping box (gross)

COMBINATION PLIERS

Combination pliers

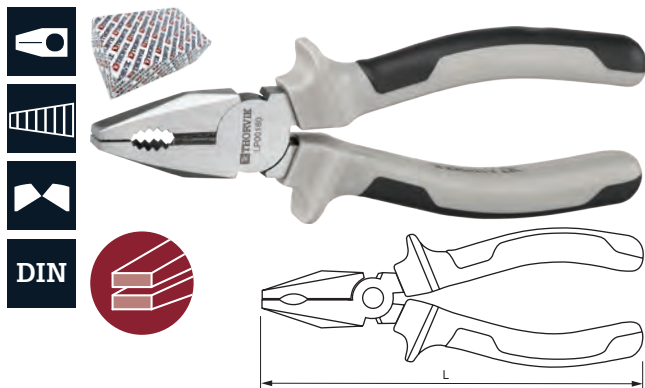

Code	Item No.	L, mm	kg	pcs	kg
52181	LP00150	150	0,23	60	14
52182	LP00180	180	0,28	60	17
52183	LP00200	200	0,35	60	21

DIAGONAL CUTTING PLIERS

Diagonal cutting pliers

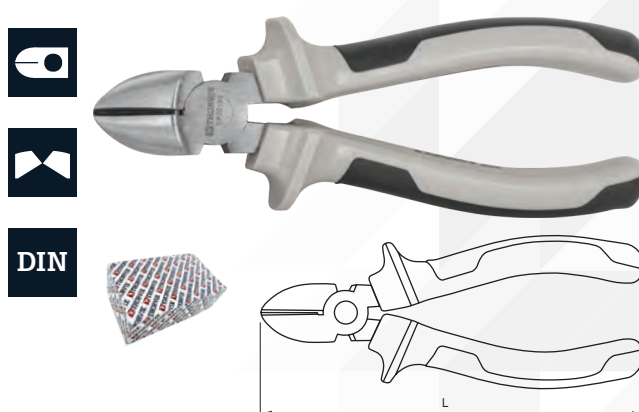

Code	Item No.	L, mm	kg	pcs	kg
52184	CP00150	150	0,22	60	13
52185	CP00180	180	0,28	60	17

LONG NOSE PLIERS

Straight long nose pliers

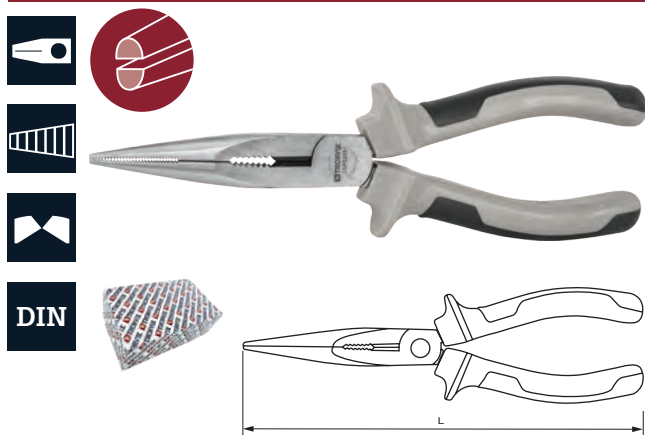

Code	Item No.	L, mm	kg	pcs	kg
52186	LNP0180	180	0,20	60	12
52187	LNP0200	200	0,22	60	13

Bend long nose pliers

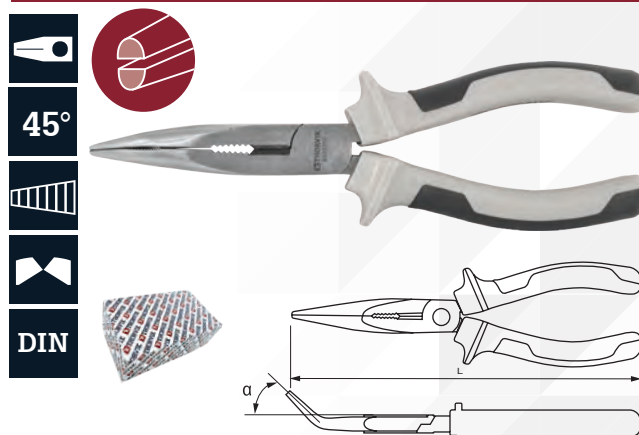

Code	Item No.	L, mm	α°	kg	pcs	kg
52188	BNP0150	150	45	0,17	60	10
52189	BNP0200	200	45	0,22	60	13

BOX JOINT PLIERS

Box joint pliers



Code	Item No.	L, mm	T, mm	kg	pcs	kg
52258	BJP0180	180	26	0,21	6/72	1,24/17
52259	BJP0250	250	33	0,37	6/60	2,20/24
52260	BJP0300	300	44	0,56	6/48	3,37/29
52261	BJP0400	400	71	1,32	4/20	5,28/28

INTERNAL/EXTERNAL PLIERS

Straight nose internal pliers

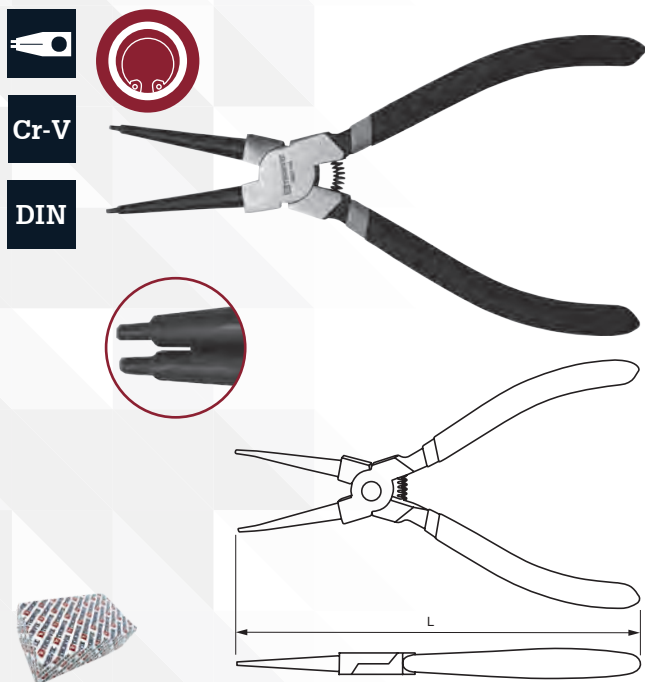

Code	Item No.	L, mm	Range, mm	kg	pcs	kg
52192	IRSP180	180	12-32	0,25	60	15

Bend nose internal pliers

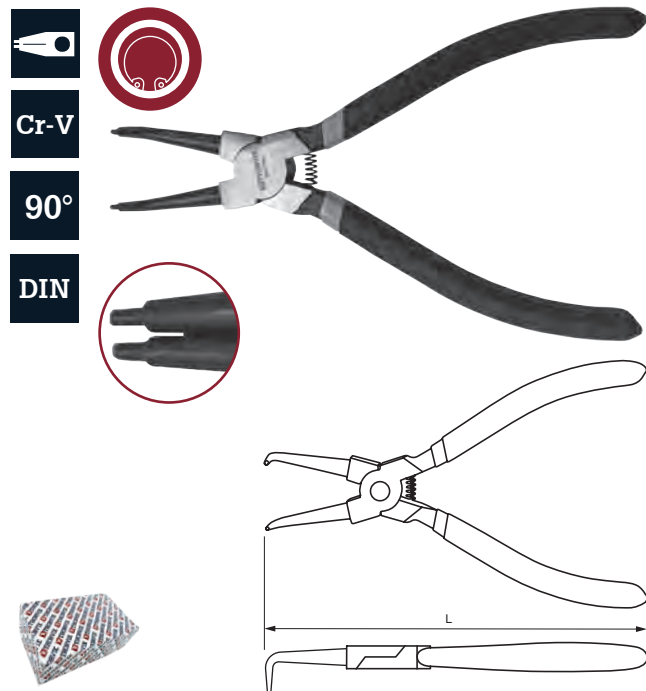

Code	Item No.	L, mm	Range, mm	kg	pcs	kg
52190	IRBP180	180	12-32	0,25	60	15

Straight nose external pliers

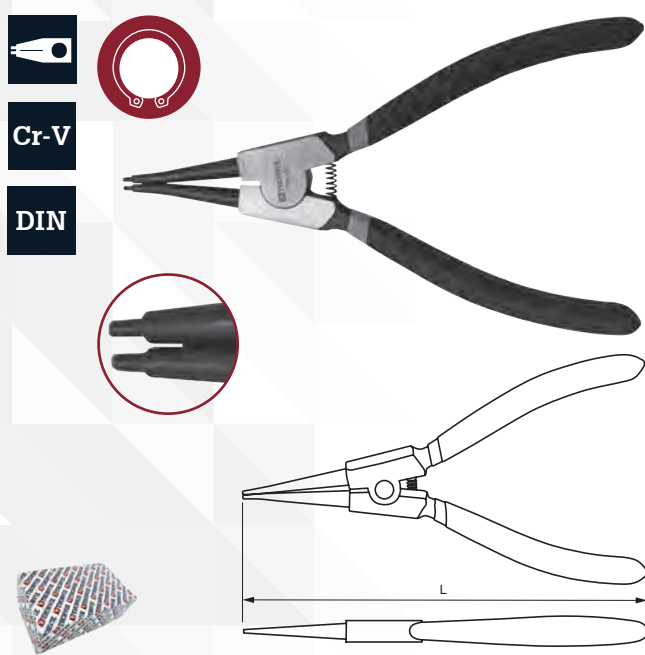

Code	Item No.	L, mm	Range, mm	kg	pcs	kg
52193	ERSP180	180	12-65	0,25	60	15

Bend nose external pliers







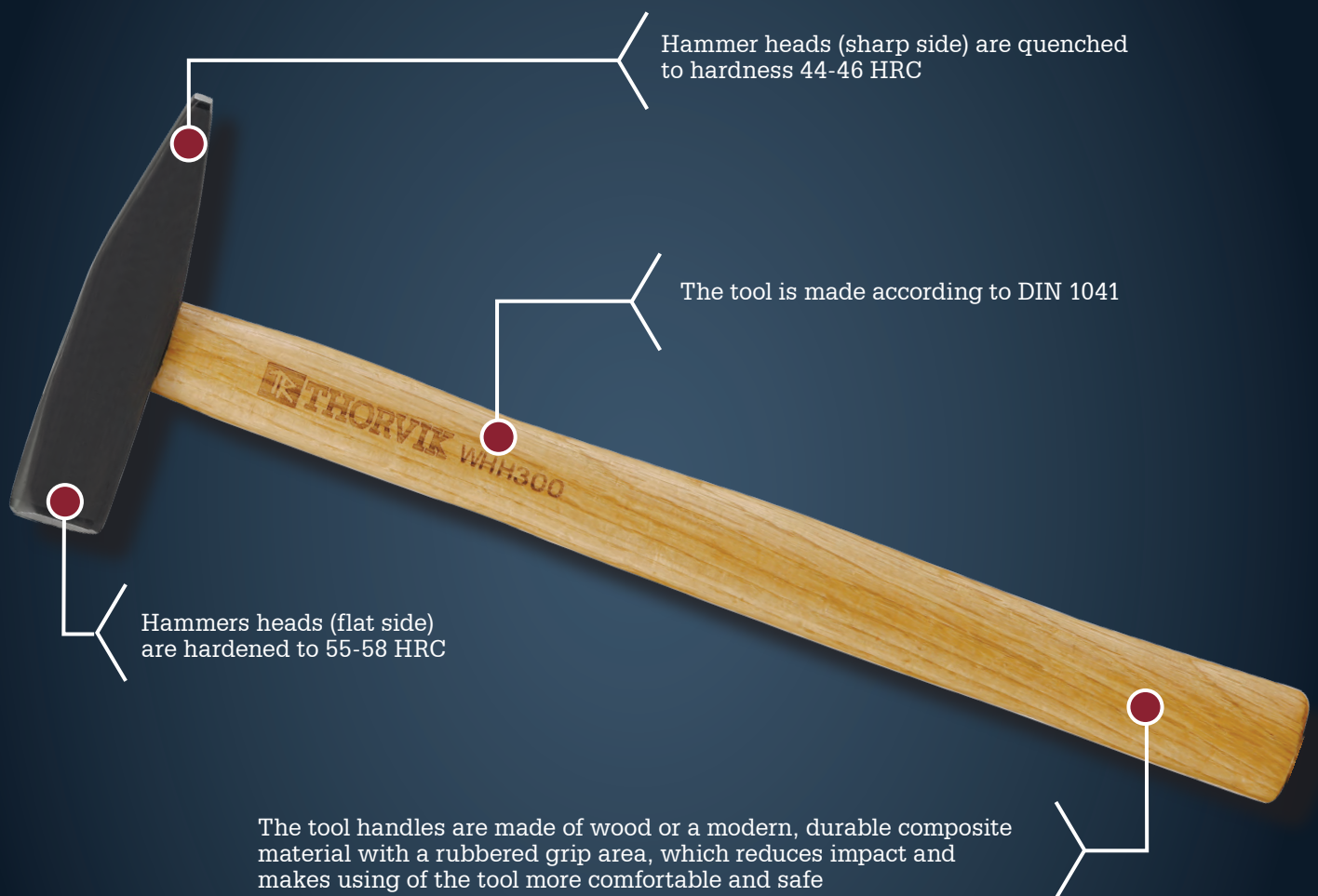

Code	Item No.	L, mm	Range, mm	kg	pcs	kg
52191	ERBP180	180	12-65	0,25	60	15

Impactor tool

The line of THORVIK® impact tool contains a range of products that vary in size, application, technology used in the production process. Bench hammers of a «German» type, manufactured according to DIN 1041, weighing from 0.1 to 1 kg, used for general-purpose works and carpentry, weighing 0.45 kg. Sledge hammers weighing from 1 to 8 kg with handles of different length. Products are available with wooden and fiberglass composite handles.



 Hammer	 Square pin	 According to DIN standart
 Carpenter hammer	 Round pin	
 Sledgehammer		

 Weight of one item

 Quantity in the package / shipping box

 Packing weight (gross) / shipping box (gross)

HAMMERS

Thorvik bench hammers so called "German" type used for general-purpose works. The tool is made according to DIN 1041.

Hammers heads (sharp side) are hardened to 55-58 HRC, hammers heads (flat side) are hardened to 44-46 HRC.

Hammer with wooden handle

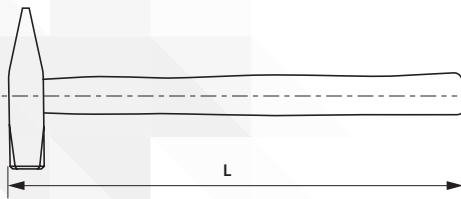

Code	Item No.	gr.	L, mm	kg	pcs	kg
52242	WHH100	100	260	0,13	6/120	0,75/15
52243	WHH200	200	280	0,22	6/72	1,32/16
52244	WHH300	300	300	0,33	6/60	1,98/20
52245	WHH500	500	320	0,54	6/48	3,20/25
52246	WHH600	600	325	0,72	6/36	4,30/26
52247	WHH800	800	350	0,91	6/24	5,46/22
52241	WHH001	1000	360	1,16	6/24	6,99/28

Hammer with fiberglass handle

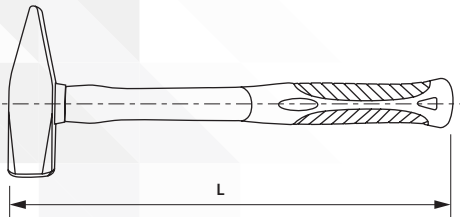

Code	Item No.	gr.	L, mm	kg	pcs	kg
52230	PHH300	300	300	0,50	6/60	3,00/30
52231	PHH500	500	320	0,77	6/48	4,62/37
52232	PHH800	800	350	1,08	6/24	6,50/26
52229	PHH001	1000	360	1,33	6/24	8,00/32

Carpenter's hammer with fiberglass handle

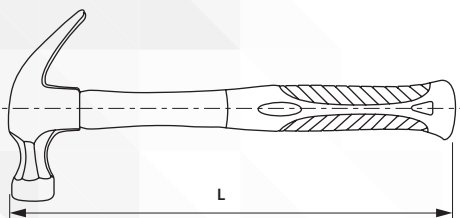

Code	Item No.	gr.	L, mm	kg	pcs	kg
52228	PHCH45	450	325	0,75	6/36	4,50/27

Steel hammer with a nail puller and fiberglass handle, covered with a TPR cover.

SLEDGEHAMMER

More powerful than a hammer, impact tool. It is used in cases when the mass of the hammer is not enough. Thorvik offers bench sledgehammers with short handles, which are used for disassembling units, cutting metals, etc., that is, if you need a strong but precise blow, and tools with handles of increased length, for destructive impact. Thorvik sledgehammers are made of steel, supplied with handles of wood or of fiberglass-based composite. Work surfaces hardened to 45 HRC.

Sledge with wooden handle

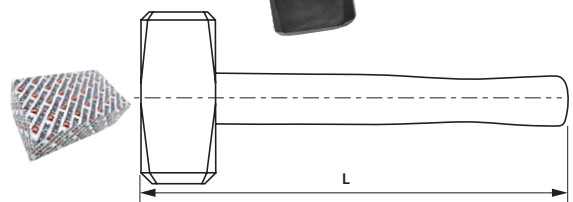

Code	Item No.	kg	L, mm	kg	pcs	kg
52250	WSH125	1,25	280	1,45	6/24	8,75/35
52249	WSH002	2	300	2,17	6/12	13,00/26
52238	SLSHW3	3	750/900*	3,80	6	23
52239	SLSHW5	5	900	6,00	4	24
52240	SLSHW8	8	900	9,00	2	18

* - the length of the handle of the product in different commodity lots may differ

Sledge with fiberglass handle

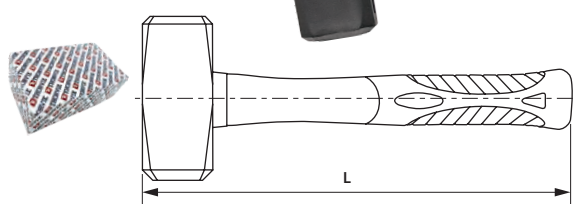

Code	Item No.	kg	L, mm	kg	pcs	kg
52234	PSH125	1,25	280	1,54	6/24	9,25/37
52233	PSH002	2	300	2,30	6/12	13,50/27
52235	SLSHP3	3	900	4,00	6	24
52236	SLSHP5	5	900	6,00	4	24
52237	SLSHP8	8	900	9,00	2	18

MALLETS

A mallets is an impact tool that is used to transfer the impact to the auxiliary (cutting) tool without damaging of it or for straightening and folding various items made of sheet metal.

Rubber mallet

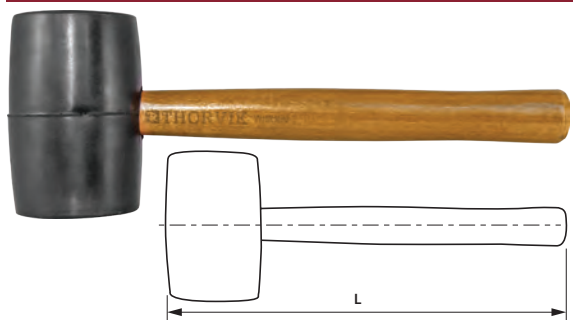

Code	Item No.	kg	L, mm	kg	pcs	kg
52248	WHRM90	0,9	340	1,00	6/24	6,00/24

Pneumatic tools

THORVIK® pneumatic tools is the brand, used for mechanization of fitting and assembly work, form a line of the most high-demanded and popular products of this type, including pneumatic impact wrenches of various capacities and sizes of drives from 1/2 "DR to 1" DR, ratchet handles, drills, grinding and angle grinders. The use of THORVIK® pneumatic tools allows you to save manpower and time, plus to it is indispensable in mass production.



1/2" Square drive 1/2" (inch)

3/4" Square drive 3/4" (inch)

1" Square drive 1" (inch)



Weight of one item



Quantity in the package / shipping box



Packing weight (gross) / shipping box (gross)

PNEUMATIC IMPACT WRENCHES

Impact wrench 1/2"DR

Item No.: AIW12717

1/2"



- Full metal body
- Classic model
- High power
- Low weight
- Low vibration level

Code	Item No.	kg	pcs	kg
52482	AIW12717	2,7	8	24
Specifications:				
Anvil size	1/2"DR			
Free speed (RPM)	7500 RPM			
Maximum torque	717 Nm			
Working torque	640 Nm			
Recommended maximum air pressure	6,3 Bar			
Average air consumption CFM	133 l/min			
Air hose size	10 mm			
Air inlet size	1/4"DR			
Overall size (lxWxH)	188x196x69 mm			
Clutch mechanism	twin hammer			



Spare parts and repair kits are available for this product:

Anvil for AIW12717

Code: 52501; Item No.: RKS112717

Repair kit for AIW12717

Code: 52502; Item No.: RKS212717

Impact wrench 1/2"DR

Item No.: AIW1268

1/2"



- Low weight
- High power
- Composite materials body
- Low vibration level
- Convenient operation

Code	Item No.	kg	pcs	kg
52198	AIW1268	2,6	6	15
Specifications:				
Anvil size	1/2"DR			
Free speed (RPM)	7500 RPM			
Maximum torque	680 Nm			
Working torque	590 Nm			
Recommended maximum air pressure	6,3 Bar			
Average air consumption CFM	180 l/min			
Air hose size	10 mm			
Air inlet size	1/4"DR			
Overall size (lxWxH)	195,7x187,5x69 mm			
Clutch mechanism	twin hammer			



Spare parts and repair kits are available for this product:

Anvil for AIW1268

Code: 52208;
Item No.: RKS11268

Set of installation pads for drive of an impact wrench AIW1268

Code: 52209; Item No.: RKS21268

Repair kit for engine

Code: 52210;
Item No.: RKS31268



Гайковерт ударный пневматический, 1/2"DR

Item No.: AIW12122

1/2"



Code	Item No.	kg	pcs	kg
53009	AIW12122	2,7	10	31
Характеристики:				
Anvil size	1/2"DR			
Free speed (RPM)	8800 об./мин.			
Maximum torque	1220 Nm			
Working torque	1010 Nm			
Recommended maximum air pressure	6,3 Bar			
Average air consumption CFM	266 l/min.			
Air hose size	10 mm			
Air inlet size	1/4"DR			
Overall size (length)	193x178x72 mm			
Clutch mechanism	twin hammer			



Spare parts and repair kits are available for this product:

Anvil for impact wrench AIW12122
Code: 53019; Item No.: RKS112122

Repair kit for AIW12122
Code: 53018; Item No.: RKS212122

Impact wrench 3/4"DR

Item No.: AIW3416

3/4"



Code	Item No.	kg	pcs	kg
52749	AIW3416M	7,0	4	30
Specifications:				
Anvil size	3/4"DR			
Free speed (RPM)	5000 RPM			
Maximum torque	1800 Nm			
Recommended maximum air pressure	6,3 Bar			
Average air consumption CFM	210 l/min			
Air hose size	12 mm			
Air inlet size	3/8"DR			
Overall size (length)	235 mm			
Clutch mechanism	twin hammer			



Spare parts and repair kits are available for this product:

Anvil for AIW3416M
Code: 52785; Item No.: RKS23416M

Repair kit for engine AIW3416M
Code: 52782; Item No.: RKS13416M

Impact wrench 1"DR

Item No.: AIWS125

1"



■ The product is supplied in an individual plastic case with a set of accessories and sockets 1"DR 32 mm and 33 mm.

Code	Item No.	kg	pcs	kg
52751	AIWS125M	13,7	1	17,2
Specifications:				
Anvil size	1"DR			
Legth	540 mm			
Anvil legth	225 mm			
Free speed (RPM)	4000 RPM			
Maximum torque	2300 Nm			
Recommended maximum air pressure	8-14 Bar			
Average air consumption CFM	288 l/min			
Air hose size	19 mm			
Air inlet size	1/2"DR			
Clutch mechanism	axles hammer			



Spare parts and repair kits are available for this product:

Anvil for AIWS125
Code: 52784; Item No.: RKS2125M

Repair kit for engine AIWS125M
Code: 52781; Item No.: RKS1125M

Impact wrench 1"DR

Item No.: AIWS124

1"



■ The product is supplied in an individual plastic case with a set of accessories and sockets 1"DR 32 mm and 33 mm.



Code	Item No.	kg	pcs	kg
52750	AIWS124M	16,6	1	20,6
Specifications:				
Anvil size	1"DR			
Legth	615 mm			
Anvil legth	225 mm			
Free speed (RPM)	3200 RPM			
Maximum torque	3200 Nm			
Recommended maximum air pressure	8-14 Bar			
Average air consumption CFM	336 l/min			
Air hose size	19 mm			
Air inlet size	1/2"DR			
Clutch mechanism	axles hammer			



Spare parts and repair kits are available for this product:

Anvil for AIWS124

Code: 52783; Item No.: RKS2124M

Repair kit for engine AIWS124M

Code: 52780; Item No.: RKS1124M

AIR RATCHET WRENCH

Air ratchet wrench, 1/2"DR

Item No.: ARW1261

1/2"



Code	Item No.	kg	pcs	kg
52201	ARW1261	1,19	20	26
Specifications:				
Anvil size	1/2"DR			
Free speed (RPM)	150 RPM			
Maximum torque	61 Nm			
Recommended maximum air pressure	6,3 Bar			
Average air consumption CFM	141 l/min			
Air hose size	10 mm			
Air inlet size	1/4"DR			
Overall size (length)	262 mm			
Clutch mechanism	ratchet mechanism			



Spare parts and repair kits are available for this product:

Anvil for ARW1261

Code: 52216; Item No.: RKS01261

The rotor blades of the engine for pneumatic ratchet handle ARW1261

Code: 52217; Item No.: RKS01261

Air ratchet wrench, 3/8"DR

Item No.: ARW3827

3/8"



Code	Item No.	kg	pcs	kg
52649	ARW3827	0,6	20,00	12,42
Specifications:				
Anvil size	3/8"DR			
Free speed (RPM)	180 RPM			
Maximum torque	27 Nm			
Recommended maximum air pressure	6,3 Bar			
Average air consumption CFM	113 l/min			
Air hose size	10 mm			
Air inlet size	1/4"DR			
Overall size (length)	183 mm			
Clutch mechanism	ratchet mechanism			

AIR DRILL

Pneumatic drill with reverse

Item No.: RAD1018



Code	Item No.	kg	pcs	kg
52202	RAD1018	1,16	20	26
Specifications:				
Chuck size, working range		1-10 mm		
Free speed (RPM)		1800 RPM		
Recommended maximum air pressure		6,3 Bar		
Average air consumption CFM		141 l/min		
Air hose size		10 mm		
Air inlet size		1/4"DR		
Overall size (length)		193 mm		
Clutch mechanism		Planetary		



Spare parts and repair kits are available for this product:

The rotor blades of the engine wrench RAD1018

Code: 52218; Item No.: RKS11018

Satellites of a planetary reducer of a drill of RAD1018

Code: 52219; Item No.: RKS21018

Three-jaw chuck, self-locking, with key, for RAD1018

Code: 52220; Item No.: RKS31018

Air straight drill

Item No.: SAD2500



Code	Item No.	kg	pcs	kg
52654	SAD2500	1	20,00	20,49
Specifications:				
Chuck size, working range		1-10 mm		
Free speed (RPM)		2500 RPM		
Recommended maximum air pressure		6,3 Bar		
Average air consumption CFM		198 l/min		
Air hose size		10 mm		
Air inlet size		1/4"DR		
Overall size (length)		225 mm		
Clutch mechanism		Planetary		
Exhaust direction		Rear exhaust		

Air angle drill

Item No.: AAD1500



Code	Item No.	kg	pcs	kg
52640	AAD1500	0,72	30	22,05
Specifications:				
Chuck size, working range		1-10 mm		
Free speed (RPM)		15000 RPM		
Recommended maximum air pressure		6,3 Bar		
Average air consumption CFM		113 l/min		
Air hose size		10 mm		
Air inlet size		1/4"DR		
Overall size (length)		170 mm		
Clutch mechanism		Planetary		
Exhaust direction		Rear exhaust		

Also, the range of TM THORVIK has a large selection of drills, which you can find on pages 85-88 of this catalog.

AIR DIE GRINDERS

Air die grinder

Item No.: ADG6022



Code	Item No.	kg	pcs	kg
52203	ADG6022	0,69	30	24
Specifications:				
Размер цапги		6 mm		
Free speed (RPM)		22000 RPM		
Recommended maximum air pressure		6,3 Bar		
Average air consumption CFM		198 l/min		
Air hose size		10 mm		
Air inlet size		1/4"DR		
Overall size (LxWxH)		168x62,8x40,5		



Spare parts and repair kits are available for this product:

The rotor blades of the engine wrench ADG6022

Code: 52221; Item No.: RKS16022

Extension air die grinder

Item No.: EADG6020



Code	Item No.	kg	pcs	kg
52652	EADG6020	0,79	30,00	24,18
Specifications:				
Collet size		6 mm		
Free speed (RPM)		20000 RPM		
Recommended maximum air pressure		6,3 Bar		
Average air consumption CFM		113 l/min		
Air hose size		10 mm		
Air inlet size		1/4"DR		
Overall size (length)		285 mm		
Exhaust direction		Rear exhaust		

Air angle die grinder

Item No.: AADG6020



Code	Item No.	kg	pcs	kg
52641	AADG6020	0,64	30,00	19,61
Specifications:				
Collet size		6 mm		
Free speed (RPM)		20000 RPM		
Recommended maximum air pressure		6,3 Bar		
Average air consumption CFM		113 l/min		
Air hose size		10 mm		
Air inlet size		1/4"DR		
Overall size (length)		157 mm		
Exhaust direction		Rear exhaust		

AIR ANGLE GRINDERS

Air angle grinder

Item No.: AAG0510



Code	Item No.	kg	pcs	kg
52642	AAG0510	2,12	10,00	21,94
Specifications:				
Grinding wheel diametr, Max		125 mm		
Spindle thread		22 mm		
Free speed (RPM)		10000 RPM		
Recommended maximum air pressure		6,3 Bar		
Average air consumption CFM		169 l/min		
Air hose size		10 mm		
Air inlet size		1/4"DR		
Overall size (length)		228 mm		

Grinding pneumatic orbital machine with dust extraction

Item No.: AOS6105



Code	Item No.	kg	pcs	kg
52648	AOS6105	1,5	10,00	15,92
Specifications:				
Disk diametr		150 mm		
Free speed (RPM)		10500 RPM		
Recommended maximum air pressure		6,3 Bar		
Average air consumption CFM		84 l/min		
Eccentricity		5 mm		
Air hose size		10 mm		
Air inlet size		1/4"DR		
Overall size (length)		214 mm		

Also, the assortment of TM Thorvik has a large selection of cutting, flap and grinding discs, which you can find on the page 83 of this catalog.

AIR HAMMERS

Pneumatic hammer with nozzles in a set

Item No.: AHK9150



Code	Item No.	kg	pcs	kg
52647	AHK9150	2,15	8,00	17,96
Specifications:				
Spindle thread		10,2 mm		
Blow per minute		4500		
Recommended maximum air pressure		6,3 Bar		
Average air consumption CFM		113 l/min		
Air hose size		10 mm		
Air inlet size		1/4"DR		
Overall size (length)		150 mm		
Weight of the air hammer		1,45 kg		
Overall size (LxWxH)		460x320x290 mm		
Weight of the kit		2,05 kg		

AIR BLOW GUNS

Air blow gun



- Composite materials
- Ergonomic design

Code	Item No.	Nose length (mm)	kg	pcs	kg
52205	ABG6510	100	0,22	40,00	10
52643	ABG6520	200	0,23	40,00	10,8
52644	ABG6530	300	0,26	40,00	12,02

Specifications:

Working pressure	2-6 KGc/cm ²
Average air consumption CFM	180 l/min

Air blow gun with nozzles

Item No.: ABGK5



5 pcs

Code	Item No.	kg	pcs	kg
52645	ABGK5	0,16	100,00	16,71

Air blow gun with nozzles

Item No.: ABGK7

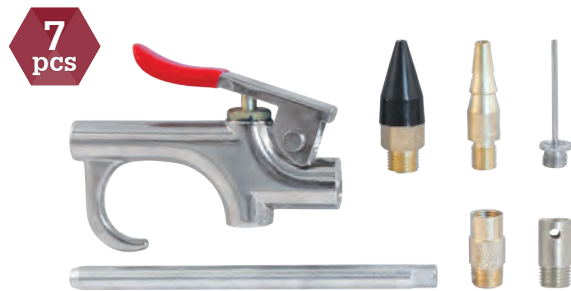

7 pcs

Code	Item No.	kg	pcs	kg
52646	ABGK7	0,16	100,00	16,71

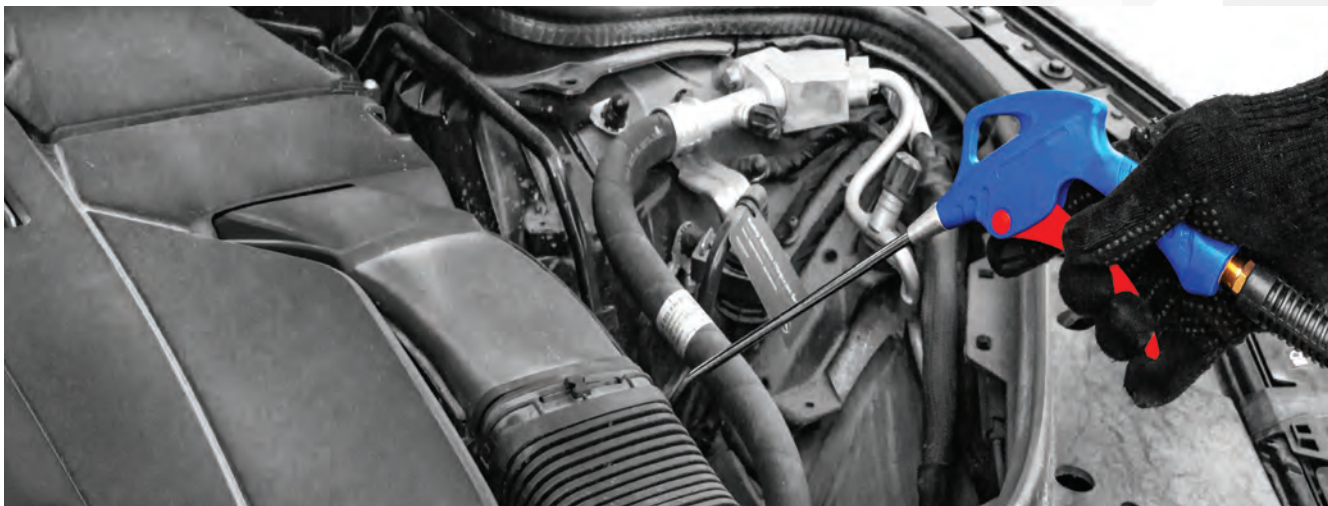

AIR HOSES FOR PNEUMATIC TOOLS

PVC hoses with 1/4" NPT fittings for pneumatic tools



Code	Item No.	Air inlet size	Iternal diametr, mm	Eternal diametr, mm	Legth (meters)	kg	pcs	kg
52262	CAH615	1/4" NPT	6,3	12	15	1,8	10	20
52263	CAH915	1/4" NPT	9,5	15,5	15	3,0	6	19

PVC hoses for pneumatic tools, in coils



Code	Item No.	Iternal diametr, mm	Eternal diametr, mm	Legth (meters)	kg	pcs	kg
52266	RAH615	6,3	12	15	1,5	10	16
52265	RAH605	6,3	12	50	5,0	4	21
52264	RAH601	6,3	12	100	10,0	2	21
52267	RAH915	9,5	15,5	15	2,2	6	14
52269	RAH955	9,5	15,5	50	7,5	2	16
52268	RAH951	9,5	15,5	100	15,0	1	16

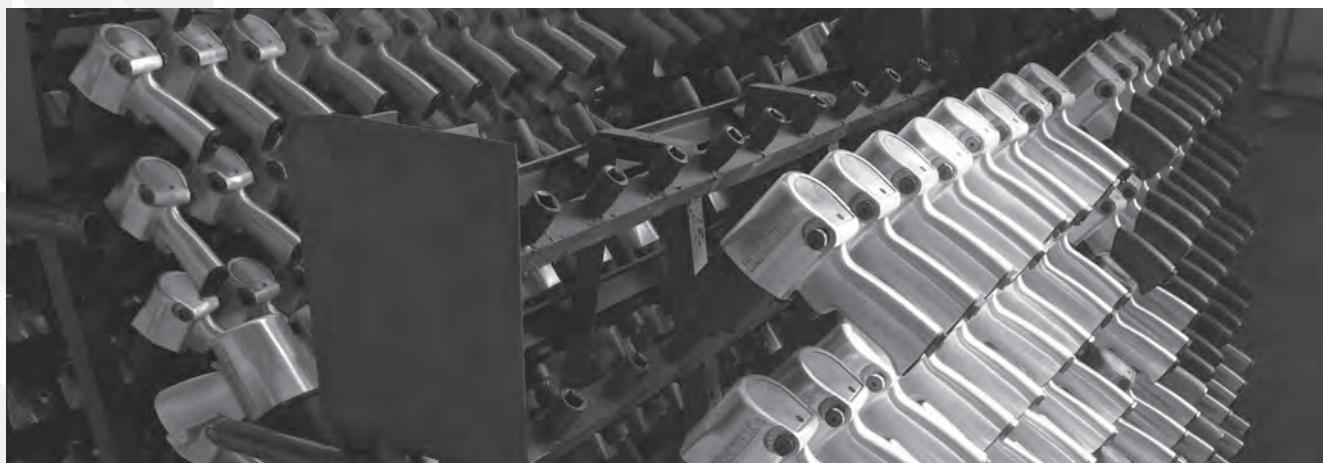

Automotive tools

TM THORVIK® automotive tool designed for maintenance and repair of all types of vehicles. It is used in work with a variety of units and assemblies of motor vehicles and agricultural equipment, including in hard working areas. TM THORVIK® automotive tool allows you to perform maintenance independently, without contacting specialized centers. Many types of repair work on vehicles that previously presented a great deal of complexity and took a lot of time have become more accessible and easier, both for the professional and for the amateur thanks to the TM THORVIK® automotive tool line.



2-Jaws gear puller

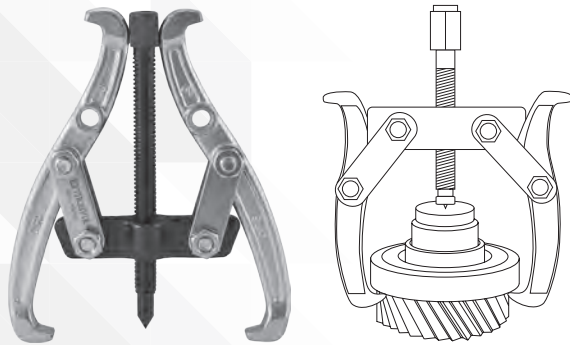

Code	Item No.	Size, mm	Working range, mm
52321	AGP23	75	40-75
52322	AGP24	100	50-100
52323	AGP26	150	60-150
52324	AGP28	200	80-200

3-Jaws gear puller

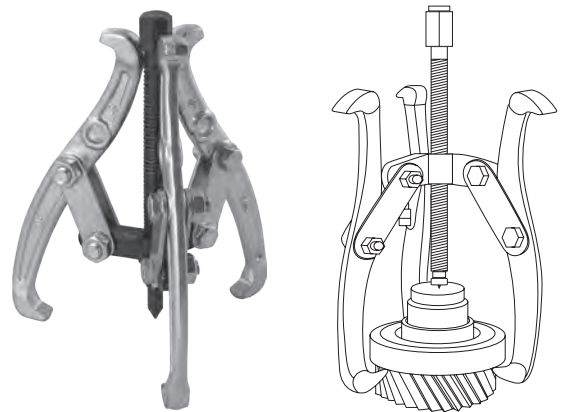

Code	Item No.	Size, mm	Working range, mm
52325	AGP33	75	40-75
52326	AGP34	100	50-100
52327	AGP36	150	60-150
52328	AGP38	200	80-200

Multifunction puller with bolt clamps in a set. Range of captures is 30-120 mm, 13 pcs.



Code	Item No.	Working range, mm
52329	AHBPS13	30-120

Content (13 pcs):

- Traverse large for a range of 30-120 mm;
- Spindle screw, 125 mm;
- Bolts, thread 1/4"x50mm, 3 pcs;
- Bolts, thread 1/4"x75mm, 2 pcs;
- Bolts, thread 5/16"x50mm, 3 pcs;
- Bolts, thread 5/16"x100mm, 2 pcs;
- Support screw;
- Plastic case.

Threading tools.

- Threaded inserts are designed to restore the functionality and original dimensions of a worn or damaged threaded connection.
- THORVIK thread inserts are made of corrosion-resistant rhombic wire in the form of a spring spiral;
- They are used in mechanical engineering, the automotive industry for repairs of cylinder engine heads, gearboxes, plug holes and oil drain nozzles, in the medical industry, energy, in the repair of turbines at power plants, in aviation workshops, in the repair of military equipment, etc.



Threading steps

1. Drilling. Hole preparation.
Drill a hole of the appropriate diameter to remove damaged threads and prepare for threading. Follow the manufacturer's recommendations and the data in DIN8140.

2. Threading.
Thread EG standard with STI specialized tap. Follow the manufacturer's recommendations and the data in DIN8140.

3. Mounting the insert on the handle holder.
Place the threaded insert on the handle holder. Use the adjusting ring to limit the working depth. The insert collar must be installed in the groove of the tool.

4. Installing the insert.
Install the threaded insert into the prepared hole.

5. Removing the driver.
Remove the driver of the threaded insert. Use a demolition jig.

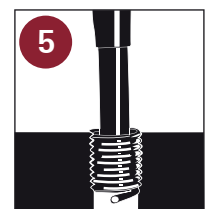
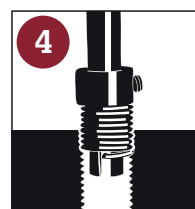
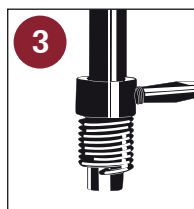
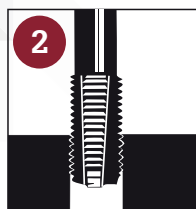

Thread repair kit

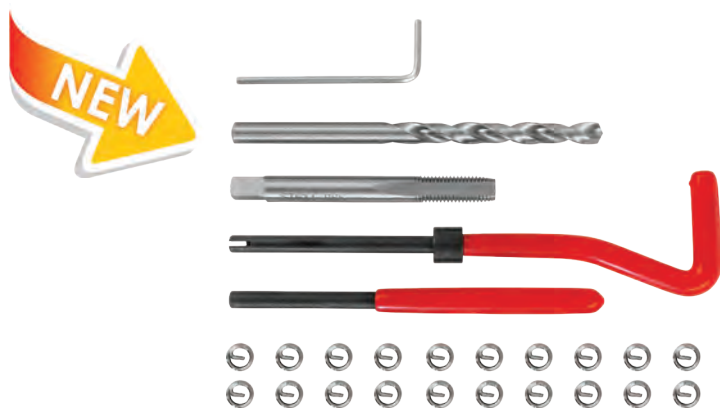

Code	Item number		Pcs
53172	TRIS508	M5x0.8	25
53173	TRIS61	M6x1.0	25
53185	TRIS710	M7x1.0	25
53183	TRIS810	M8x1.0	25
53174	TRIS8125	M8x1.25	25
53184	TRIS9125	M9x1.25	25
53175	TRIS101	M10x1.0	15
53176	TRIS10125	M10x1.25	15
53177	TRIS1015	M10x1.5	15
53178	TRIS12125	M12x1.25	15
53179	TRIS1215	M12x1.5	15
53180	TRIS12175	M12x1.75	15
53181	TRIS14125	M14x1.25	15
53182	TRIS1415	M14x1.5	15

Thread repair kit



Code	Item number		Pcs
53170	TRIS88	M6x1.0 M8x1.25 M10x1.5	88
53171	TRIS131	M5x0.8 M6x1.0 M8x1.25 M10x1.5 M12x1.75	131

Thread inserts set



Code	Item number		Pcs
53186	WTRI508	M5x0.8	25
53187	WTRI610	M6x1.0	25
53188	WTRI8125	M8x1.25	25
53189	WTRI101	M10x1.0	10
53190	WTRI10125	M10x1.25	10
53191	WTRI1015	M10x1.5	10
53192	WTRI12125	M12x1.25	10
53193	WTRI1215	M12x1.5	10
53194	WTRI12175	M12x1.75	10
53195	WTRI14125	M14x1.25	10
53196	WTRI1415	M14x1.5	10

Thread repair kit M6-M12, 15 pcs.



Code	Item No.	Working range, mm
53218	RTK15	M6-M12
Content (15 pcs):		
Dies, 7 pcs.: M6x1.0; M8x1.25; M10x1.25; M10x1.50; M12x1.25; M12x1.50; M12x1.75;		
Tips, 7 pcs.: M6x1.0; M8x1.25; M10x1.25; M10x1.50; M12x1.25; M12x1.50; M12x1.75;		
Chrome vanadium steel file, 1 pcs., thread pitch: 0.75;		
Plastic case.		

A set for restoring a thread of a spark plug hole M14, 5 pcs.



Code	Item No.	
53197	SPTRS145	9.5-19
Content (5 pcs):		
Tap with hex shank for spark plug thread M14x1.25, self-centering;		
Thread inserts 9.5 mm (3/8"), 11 mm (7/16"), 12.5 mm (1/2"), 19 mm (3/4").		

A set for restoring a thread of a spark plug hole M14, 5 pcs.



Code	Item No.	
53199	SPTRI1412	12.5 mm (1/2")
53198	SPTRI1434	19 mm (3/4")

Stages of thread repair of a sparkplug hole

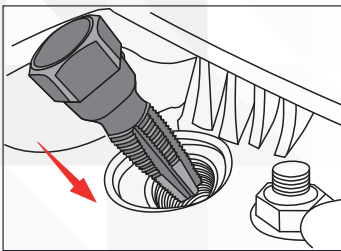

1. Thread cutting.
Cut the thread with a special tap M14x1.25

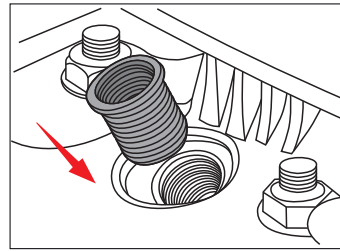

2. Installing the insert.
Install the threaded insert into the prepared hole.

A set for restoring a thread of a sump hole, 7 pcs.



Code	Item No.	
53211	ODPRK1315	M13x1.5
53212	ODPRK1515	M15x1.5
53213	ODPRK1715	M17x1.5
53214	ODPRK2015	M20x1.5
Content (7 pcs):		
Taps M13x1.5, M15x1.5, M17x1.5, M20x1.5;		
Threaded plug M13x1.5, M15x1.5, M17x1.5, M20x1.5 with aluminum sealing ring, 6 pcs.		

A set for restoring a thread of a sump hole, 64 pcs.



Code	Item No.		Working range, mm	Quantity in a set, pcs
53215	ODPRK1320	M13x1.5	M13-M20	64
		M15x1.5		
		M17x1.5		
		M20x1.5		
Content (64 pcs):				
Taps, 4 pcs.: M13x1.5, M15x1.5, M17x1.5, M20x1.5;				
Threaded plug M13x1.5, M15x1.5, M17x1.5, M20x1.5, with sealing ring, 60 pcs.				



A set for restoring a thread of a sump hole, 114 pcs.



Code	Item No.		Working range, mm	Quantity in a set, pcs
53216	ODPRK1322	M13x1.25	M13-M22	114
		M13x1.5		
		M15x1.5		
		M17x1.5		
		M20x1.5		
		M22x1.5		
Content (114 pcs):				
Taps, 6 pcs.: M13x1.25, M13x1.5, M15x1.5, M17x1.5, M20x1.5; M22x1.5;				
Treaded plug M13x1.25, M13x1.5, M15x1.5, M17x1.5, M20x1.5, M22x1.5, with sealing ring, 108 pcs.				

Tread restoration file



Code	Item No.	Working range, mm
53210	TRF	0.75, 1.0, 1.25, 1.5, 1.75, 2.0, 2.5, 3.0 mm

Stud extractor, 1/2"DR



Code	Item No.	Working range, mm
52352	ASE619	6-19

Spiral socket for worn fasteners 1/2"DR



Code	Item No.	Working range, mm
53219	BES1217	17
53220	BES1219	19
53221	BES1221	21
53222	BES1222	22

Tubing and hose handling tools

Tube flaring set, 10 pcs



Code	Item No.	Working range, mm
52507	DFTS10	4-14
Content (10 pcs):		
Roller pipe cutter with a cutter for deburring;		
Clamp from fixing tubes;		
Punches for double flaring of tubes with diameters 4, 4.75, 6, 8, 10, 12, 14 mm;		
Flaring tool;		
Plastic case.		

Set for pipe flaring 4.75-6 with hydraulic drive, 16 pcs.



Code	Item No.	Working range, mm
53247	BPFTH	4,75-6
Content (16 pcs):		
Housing tool;		
Body clamp;		
Countersink manual;		
Handle;		
Hydraulic drive;		
Tube matrix III 4.75(3/16"), 5.00, 6.35 (1/4") mm;		
Punches for tubes;		
Plastic case.		

Manual tube bender for pipes with a diameter of 4.75-10 mm



Code	Item No.	Working range, mm
53244	BPB1	4.75-10

Manual tube bender for pipes with a diameter of 3-6 mm



Code	Item No.	Working range, mm
53245	BPB2	3-6

A set of plastic clips for rubber hoses and pipes, 3-57 mm, 3 pcs.



Code	Item No.	Working range, mm
53257	HCS3	5-57

Metal hose clamps set, 4 pcs.

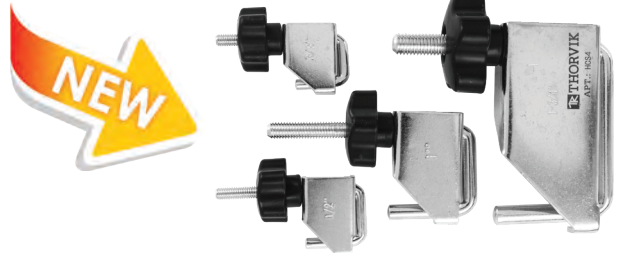

Code	Item No.	Working range, mm
53249	HCS4	10-45

CHASSIS REPAIR AND MAINTENANCE TOOL.

Suspension tool.

Nozzle with radial spikes for mounting/dismounting of shock absorber of VAG cars

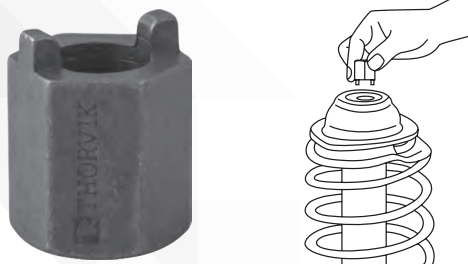

Code	Item No.	Drive size, mm
52353	ASSS22	22

Ball joint remover

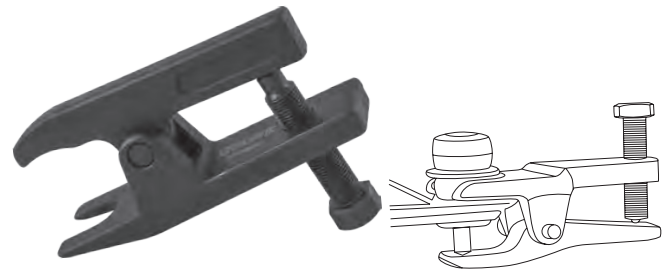

Code	Item No.	Capture size, mm
52313	ABJS3	19

Ball joint extractor, 33 mm



Code	Item No.	Capture size, mm
52309	ABJP1	33

Ball joint remover

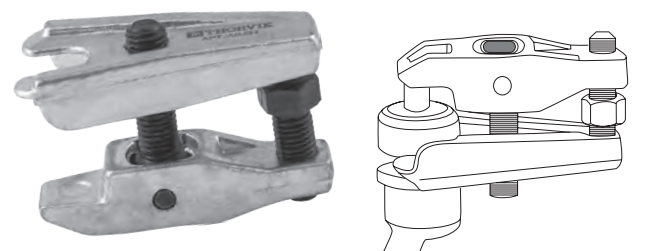

Code	Item No.	Capture size, mm
52311	ABJS1	22

Ball joint remover with extended capture, 17 mm

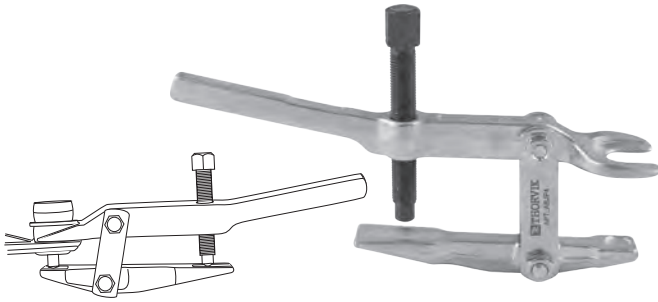

Code	Item No.	Capture size, mm
52310	ABJP4	17

Ball joint separator

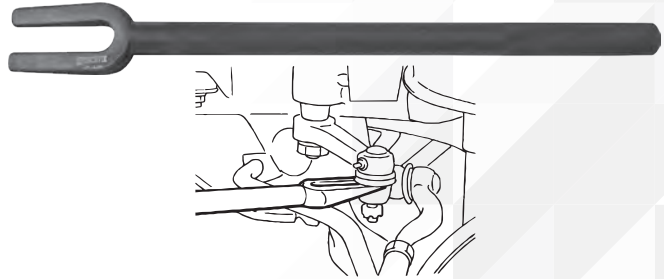

Code	Item No.	Length, mm	Capture size, mm
52307	ABJE30	300	16,5
52308	ABJE40	400	22

Coil spring compressor, 2 pcs



Code	Item No.	Working size, mm
52350	ASC27	270
52351	ASC37	370

Ball joint remover with variable height grip

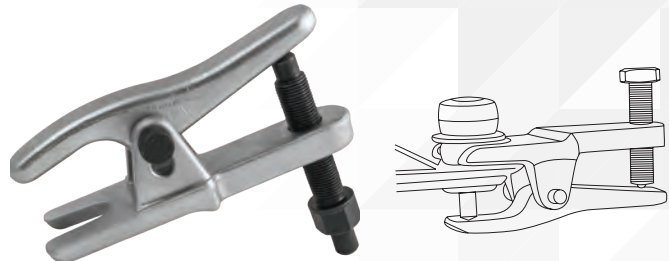

Code	Item No.	Capture size, mm
52312	ABJS2	22

Device for installing clamps with cutter



Code	Item No.
52315	ACBT

Boot clamp pliers

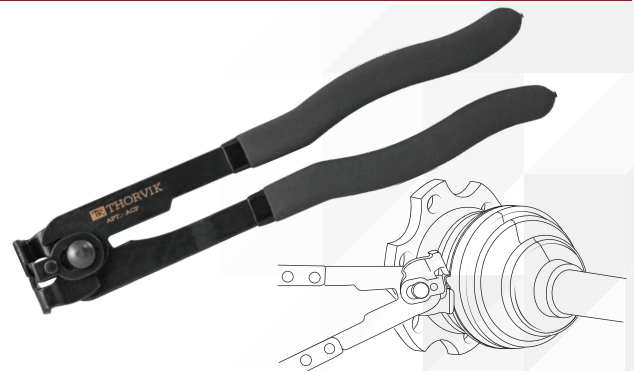

Code	Item No.
52318	ACP

Heavy duty boot clamp pliers



Code	Item No.
52633	ACP2

MacPherson spring dumper extractor/installer



Code	Item No.
52637	AMSK
Content (8 pcs):	
Working cylinder, 1 pcs;	
Spring grippers, 6 pcs: Ø 80-115 mm - 2 pcs, Ø 110-150 mm - 2 pcs, Ø 140-195 mm - 2 pcs;	
Taper spring adapter, 1 pcs;	
Plastic case.	

Remove and install the hub and bearing installer set, 20 pcs



Code	Item No.
52636	AFWBK
Content:	
Lead screw, 1 pcs;	
Bearing shell, 3 pcs: Ø 76, 86, 91 mm;	
Mandrel, 9 pcs: Ø 55.5, 59, 62, 65, 66, 71.5, 73, 78, 84 mm;	
Bolts, 6 pcs: M12x1.5 - 3 pcs, M14x1.5 - 3 pcs;	
Plastic case.	

Bush extractor set, 44-82 mm, 24 pcs



Code	Item No.
52638	APPS24
Content:	
Lead screw with nuts, 4 pcs: M10, M12, M14, M16;	
Mandrel inner / outer diameter, 20 pcs: Ø 34/44, 36/46, 38/48, 40/50, 42/52, 44/54, 46/56, 48/58, 50/60, 52/62, 54/64, 56/66, 58/68, 60/70, 62/72, 64/74, 66/76, 68/78, 70/80, 72/82 mm;	
Plastic case.	

Universal tool for bishing replacement in a set, 44-90 mm



Code	Item No.
53008	APPS27
Content:	
Leads screw with nuts, 5 pcs: M10, M12, M14, M16, M18;	
Mandrel inner/outer diameter, 22 pcs: III 34/44, 36/46, 38/48, 40/50, 42/52, 44/54, 46/56, 48/58, 50/60, 52/62, 54/64, 56/66, 58/68, 60/70, 62/72, 64/74, 66/76, 68/78, 70/80, 72/82 mm, 75/85 mm, 80/90 mm;	
Plastic case.	

Brake system tools

Brake caliper piston tool

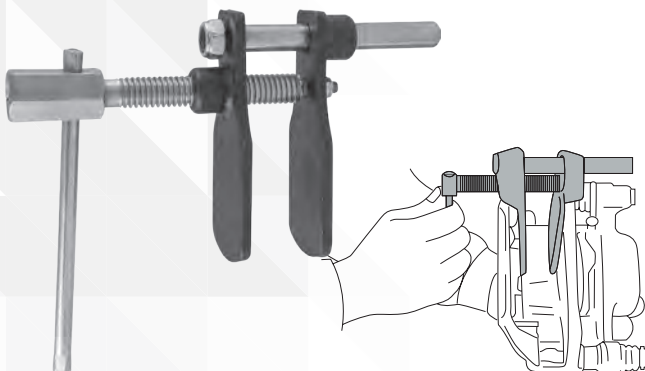

Code	Item No.
52320	ADBPS2

Brake caliper piston tool

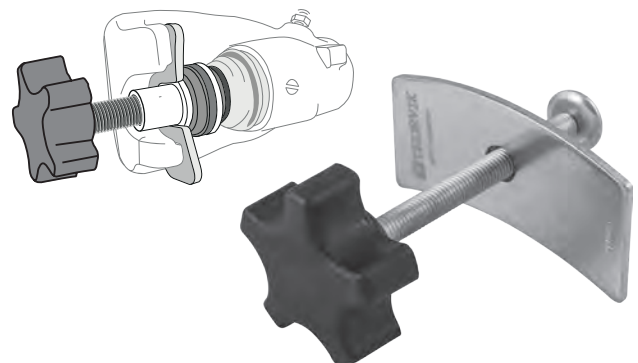

Code	Item No.
52319	ADBPS1

Brake caliper piston tool

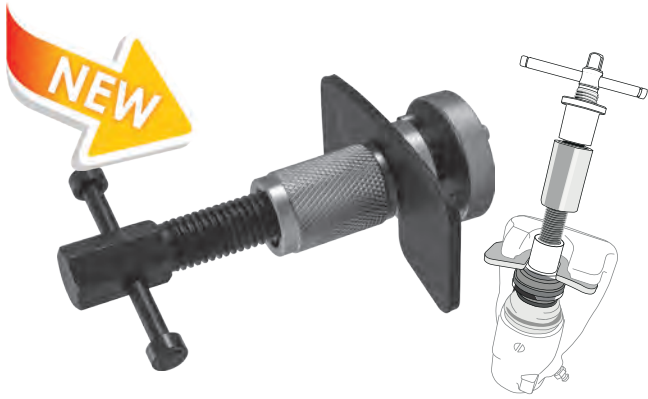

Code	Thread direction	Item No.
52317	Right	ACPTS3
53234	Left	ACPTS3L

Caliper wind back tool set

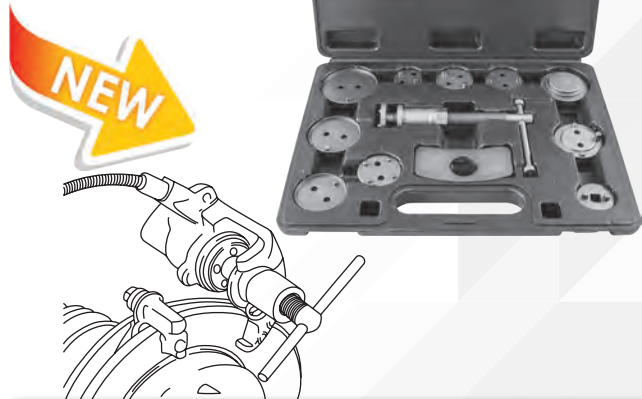

Code	Quantity, pcs.	Thread direction	Item No.
52316	12	Right	ACPTK12
53229	18	Right, left	ACPTK18

Lead screw for brake caliper piston tool



Code	Thread direction	Item No.
53231	Right	ACPTKR
53230	Left	ACPTKL

Caliper wind back tool set, 7 pcs



Code	Item No.
53233	ABCRT2
Content, (7 pcs):	
Lead screw with handle, left and right screw direction	
Bushing for lead screw right thread	
Bushing for lead screw left thread	
Thrust plate	
Basic head	
Head with two guides adjustable in width	
Head with three guides adjustable in width	
Plastic case	

Caliper wind back tool with pneumatic drive in a set, 16 pcs



Content (16 pcs):	
0 - \varnothing 60 mm, with flange connection and one guide, for GM vehicles;	
2 - \varnothing 50 mm, with flange connection and three guides, for Citroen XM and Xantia vehicles;	
3 - \varnothing 35/42/53 mm, for various vehicles;	
4 - \varnothing 30 mm, with flange connection and two guides, for Alfa Romeo 164 2.0, Saab 9000, Hond Prelude;	
5 - \varnothing 32 mm, with flange connection, two guides, and drive 3/8"DR, for Mazda 323/626, Toyota;	
6 - \varnothing 40 mm, with flange connection and two guides, for VW, Nissan;	
7 - \varnothing 40 mm, with flange connection and two guides, for various european and japan vehicles;	
8 - \varnothing 45 mm, with flange connection and one guides, for GM vehicles;	
9 - \varnothing 52 mm, with flange connection and one guides, for Citroen C5;	
A - \varnothing adapter 3/8" DR with flange connection and two guides;	
E - \varnothing 40 mm, with flange connection and four guides, for Nissan Maxima;	
F - \varnothing 28 mm, with flange connection and two guides, for Opel vehicles;	
K - \varnothing 53 mm, with flange connection and three guides, for Citroen CXM L;	
M - \varnothing 31 mm, with flange connection and two guides, for Ford Mondeo;	
N - \varnothing 30 mm, with flange connection and HEX 12 mm, for Saab/Honda vehicles;	
Pneumatic drive;	
Plastic case.	

Code	Item No.
53232	ACPTK16P

Universal drive for the return of pistons of disc brakes, 3/8"DR



Code	Item No.
53236	ABPT

Disc brake piston return device



Code	Item No.
53235	ARBCP

Brake service tool set, 8 pcs.



Code	Item No.
53251	BTS

Content (8 pcs):

- Universal pliers for disassembly brake springs;
- Device for assembly/disassembly of pressure springs (ø 15.9 mm (5/8") drum brake pads;
- Device for assembly/disassembly of pressure springs (ø 19 mm (3/4") and (ø 20.6 mm (13/16") drum brake pads;
- Device for assembly/disassembly of pressure springs (ø 15.9 mm (5/8") drum brake pads;
- Device for assembly/disassembly of pressure springs (suitable for the braking system of most car brands);
- Three mounting blades for adjusting;
- Plastic case.

Universal pliers for disassembly brake springs;



Code	Item No.
53250	BSCP

Hook puller for disassembly drum brake springs, headlight adjustment.



Code	Item No.
53248	BSRH

Device for assembly/disassembly of pressure springs drum brake pads;



Code	Item No.
53252	BRSC

A set of 5-point sockets and bit sockets for servicing brake mechanisms 1/2"DR, 3 pcs.



Code	Item No.
53237	PBCSS3

Content (3 pcs):

- Sockets 5-points, 1/2"DR, 2 pcs: 14, 19 mm;
- Bit socket, 1/2"DR, 10 mm;
- Plastic case.

A set of 5-point sockets and bit sockets for servicing brake mechanisms 1/2"DR, 3 pcs.



Code	Item No.
53238	PBCSS5
Content (3 pcs):	
Sockets 5-points, 1/2"DR, 4 pcs: 10, 12.5, 14, 19 mm;	
Bit socket, 1/2"DR, 10 mm;	
Plastic case.	

Set of adapters for servicing brake mechanism 3/8"DR, H7, H8, 2 pcs.



Code	Item No.
53255	ASBS78

Set of bit sockets for servicing brake mechanism 3/8"DR, H7, H9, 2 pcs.



Code	Item No.
53256	ASBS79

Hand use device for brake fluid replacement.



Code	Item No.
53242	BCBS
Content:	
Device	
Drain reservoir with hose	

Manual use device with the help of which work is carried out on pressure testing (pumping) of hydraulic circuits of brake drives, clutch working cylinders and replacement of working fluids.

Device with a pneumatic drive for brake fluid replacement.



Code	Item No.
53240	PBB1
Content:	
Reservoir for filling liquid, 1.0 liter;	
Reservoir for draining the waste liquid, assembled with a vacuum gun;	
Transparent hose;	
Adapter, 4 pcs.: 25/32" – 1-7/32" (21-30 mm), 31/32" – 1-1/4" (24-32 mm), 1-3/32" – 1-15/32 (28-37 mm), 1-1/4" – 1-19/32" (32-41 mm).	

The device with a pneumatic drive, with the help of which work is carried out on pressure testing (pumping) of hydraulic circuits of brake drives, clutch working cylinders and replacement of working fluids.

Adapter for PBB1



Code
53241

Item No.
PBBAD

Brake fluid tester



Code
53243

Item No.
BFT

Vacuum tester for tightness test, set, 19 pcs.



Code
53253

Item No.
VPP

Content (19 pcs):

- Manual pump with pressure gauge, assembled;
- Reservoir for draining the waste liquid, with a cap;
- Transparent hose, 4 pcs;
- Fittings and adapters, 4 pcs;
- Plastic case.

■ The device is used to test or service various vehicle systems using either a vacuum pump or a pump that builds up overpressure.

Tools for shafting.

Clutch alignment tool, 9 pcs

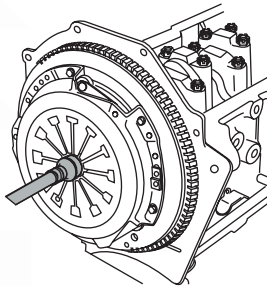

Code
52314

Item No.
ACATS10

Content (9 pcs):

18x11; 18x12; 18x15; 18x17; 18x19; 18x20; 18x21; 18x25; 82x20,5 mm.

Steering tool

Device for dismantling the steering gear



Code
52330

Item No.
AITRD1

Capture range, mm
33-42

Eccentric wrench for dismantling the steering gear



Code
52357

Item No.
ATRW24

Capture range, mm
27-42

Pitman arm puller



Code	Item No.	Capture size, mm
52345	APAP1	33

Thread restoration set of the CV-joint axle, 8 pieces

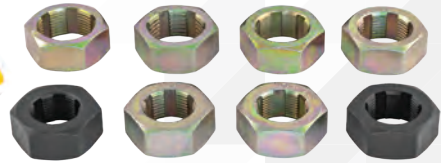

Code	Item No.
53217	CVJRTK
Content (8 pcs):	
Dies for wrench or socket 1-1/4", 8 pcs.: M24x1.5, M24x2.0, M22x1.0, M22x1.5, M20x1.5, M20x1.25, 13/16"x20 UNEF, 3/4"x20 UNEF;	
Plastic case.	

■ The thread restoration set is intended for repairing worn out or damaged threads of the CV-joint axle of motor vehicles..

BODY REPAIR AND MAINTENANCE TOOL.

Body alignment tools

Battery terminals and wiper arms puller



Code	Item No.
52362	AWAP1

Puller trim caps door trim with U-shaped grip



Code	Item No.	Length, mm
52356	ATPR10	100

Dent puller set, 13 pcs



Content (13 pcs):
Striker, 10 pound;
Guide;
Hook 90° short;
Hook 90° long;
Hook 45° short;
Hook 45° long;
Paddle short;
Paddle long;
Handle with chain;
Handle;
Double bushing;
Punch;
Shim;
Plastic case.

Code	Item No.
52634	ADPS13

Set of tools for removing a vehicle interior decorative panels, 5 pcs

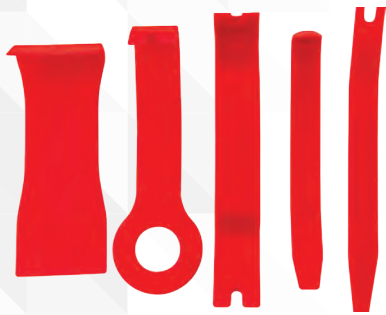

Code	Item No.
52358	AURTS5
Content (5 pcs):	
Wedge-shaped puller;	
Wedge-shaped puller with a clip for clips;	
Clips Remover;	
Wide puller;	
Hook remover.	

Set of tools for removing a vehicle interior decorative panels, 6 pcs.



Set of tools for removing a vehicle interior decorative panels, 11 pcs.



Code	Item No.
52797	AURTS6

Code	Item No.
52798	AURTS11

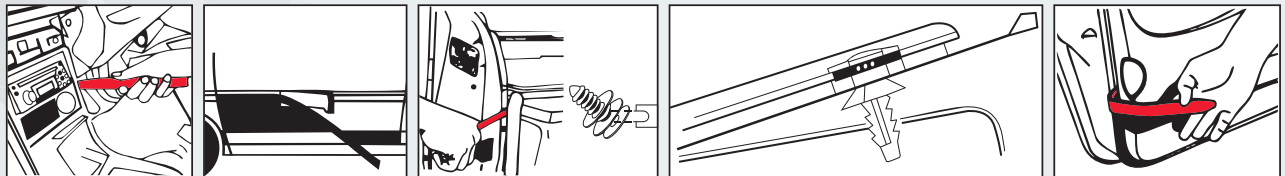

ENGINE REPAIR AND MAINTENANCE TOOL

Tool for working with a cylinder-piston engine part.

Piston ring compressor



Piston Ring Pliers

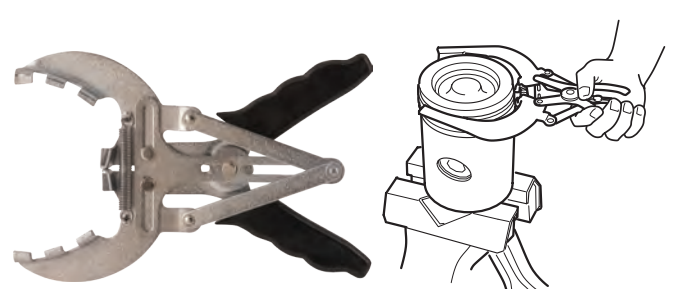

Code	Item No.	Height,mm	Working range, mm
52346	APRC3	76	53-175
52347	APRC4	100	90-175

Code	Item No.	Working range, mm
52348	APRP4	50-100
52349	APRP6	80-120

Gas distribution mechanism tool

Valve seal removal pliers

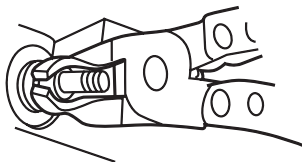

Code	Item No.	Length, mm
52361	AVSP25	250
52506	AVSP27	270

Valve spring lifter

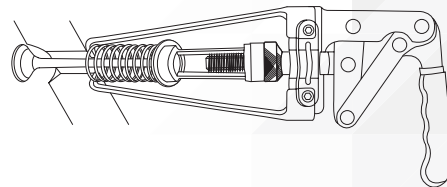
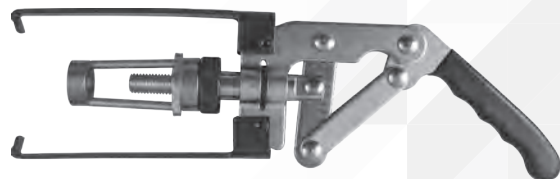

Code	Item No.
52359	AVSC25

Valve spring compressor set, 16-30 mm, 8 pcs



Code	Item No.	Length, mm
52639	AVSCS2	300
Content (8 pcs):		
Clamp, 1 pcs;		
Stop screw, 2 pcs;		
Clamping sleeves, 5 pcs: 16, 19, 23, 25, 30 mm;		
Plastic case.		

Valve spring compressor set

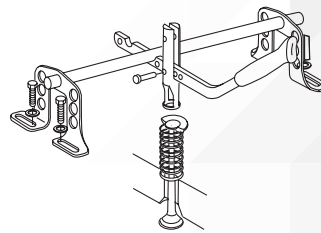

Code	Item No.
52360	AVSCS1

Tool for ruel system

Oxygen sensor wrench



Code	Item No.	Drive size	Working size, mm
52344	AOSI1278	1/2"DR	22

Tool for working with the lubrication system

A set of devices for loosening oil plugs, 12 pcs



Code	Item No.
52332	AODTS12
Content (12 pcs):	
3/8"DR:	
HEX inserts, 7 pcs: 8 mm, 9 mm, 3/8"(9.5 mm), 10 mm, 12 mm, 14 mm, 17 mm;	
Tetrahdral inserts, 4 pcs: 8 mm, 3/8"(9.5 mm), 11 mm, 13 mm;	
Handle;	
Plastic case.	

Oil filter cup, 14 points



Code	Item No.	Working size, mm
52337	AOFW6514	65
52338	AOFW7614	76

Oil filter wrench with cylindrical grippers

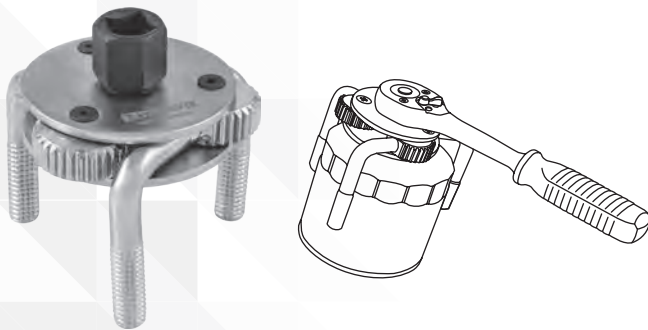

Code	Item No.	Working range, mm
52341	AOFWJ32	65-120

Oil filter wrench with flat grips

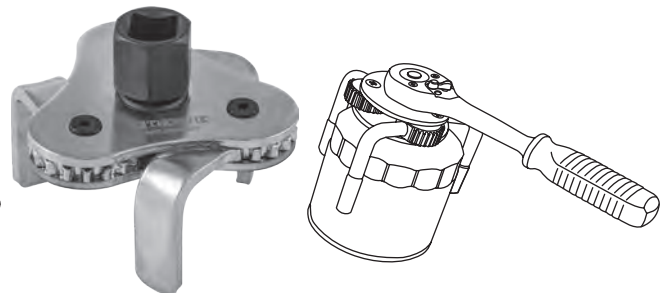

Code	Item No.	Working range, mm
52342	AOFWJ3	65-100

Oil filter chain wrench



Code	Item No.	Drive size	Chain length, mm	Working range, mm
52334	AOFCW45	1/2"DR, 16 mm HDR	450	up to 120

Chain wrench



Code	Item No.	Length, mm	Working range, mm
52333	AOFCW25	230	60-120

Strap wrench



Code	Item No.	Length, mm	Working range, mm
52339	AOFWB23	230	up to 110
52340	AOFWB30	280	up to 220

Oil filter pliers



Code	Item No.	Working range, mm
52335	AOFP25	50-85
52336	AOFP30	60-115

Oil filter cup wrenches set, 14 pcs



Code	Item No.	Working range, mm
52343	AOFWS14	65-100

Content (14 pcs):
 Oil filters:
 65 mm - 14 g; 65/67 mm - 14 g; 68 mm - 14 g; 74 mm - 15 g; 76 mm - 30 g;
 76 mm - 14 g; 74/76 mm - 15 g; 75/77 mm - 15 g; 80 mm - 15 g; 80/82 mm - 15 g;
 90 mm - 15 g; 93 mm - 15 g; 93 mmm - 36 g; 100 mm - 15 g;
 Adapter 1/2"(F) - 3/8"(M);
 Plastic case.

A tool for working with the cooling system and climatic equipment

Flexible hose clamp



Code	Item No.
52635	AFHP

Cooling system tightness test kit, 18 pcs.



Состав (18 предметов):

- RPTS18-19 Connector R123/125 Black;
- RPTS18-18 Connector R123/124 Blue;
- RPTS18-17 Special wrench for mounting the adapter;
- RPTS18-16 Adapter, pink. Mazda;
- RPTS18-15 Adapter, yellow. Ford;
- RPTS18-14 Adapter, blue, MB (W140, 124, 210, 211, 215, 216);
- RPTS18-13 Adapter, green. Ford, Land Rover, Opel;
- RPTS18-12 Adapter, red. VW, Audi;
- RPTS18-11 Adapter, gray. BMW (E32, 34, 36, 38, 39, 46, 90);
- RPTS18-08 Adapter, brown. Volvo, Saab, PSA, Renault;
- RPTS18-10 Adapter, black. VW, Audi. BMW, Porsche;
- RPTS18-09 Adapter, black. VW;
- RPTS18-07 Adapter, orange. MB (ML, W163, W164), GM;
- RPTS18-06 Adapter, Chrysler, japanese vehicles;
- RPTS18-05 Adapter, PSA, MB, GM, Chrysler, Japanese vehicles;
- RPTS18-04 Adapter, MB (W123, 124, 126, 201). GM, Jeep;
- RPTS18-03 Thermometer;
- RPTS18-02 Manual pump with manometr and hose;
- Plastic case.

Code	Item No.
52891	RPTS18

AUXILIARY TOOL

Flexible magnetic pick up tool



Code	Item No.	Length, mm	Capacity, KG
52888	FMPT4522	450	2,2
52889	FMPT45236	450	3,6

Telescopic magnetic handle



Code	Item No.	Length range, mm	Capacity, KG
52890	MTPT1365	130-641	1,5

Telescopic mirror



Code	Item No.	Diameter, mm	Working range, mm
52355	ATIM32	30	170-495

Stethoscope for detecting defects in mechanic



Code	Item No.
52331	AMS

Universal brush



Code	Item No.	Length, mm
53254	MCB	230

Bottle opener



Code	Item No.
91034	547101

TOOL FOR TYRE REPAIR

L-handle socket wrench

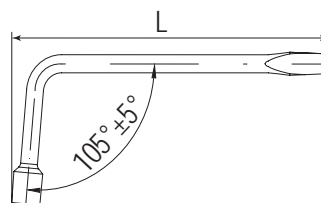

Code	Item No.	Size, mm	L, mm	kg	pcs	kg
52512	LHTW3517	17	350	0,52	50	27
52513	LHTW3519	19	350	0,54	50	28
52514	LHTW3521	21	350	0,54	50	28

Adjustable L-handle socket wrench

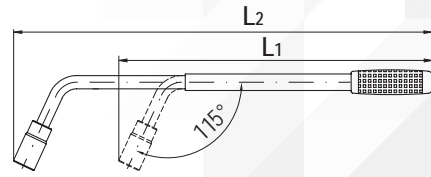

Code	Item No.	Size, mm	L1, mm	L2, mm	kg	pcs	kg
52508	TLHTW1719	17x19	380	550	1,05	20	22

Cross-handle socket wrench

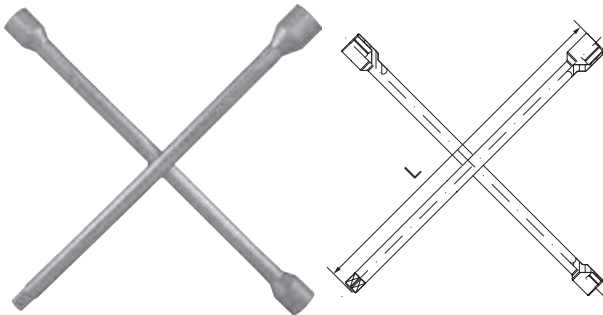

Code	Item No.	Size, mm	L, mm	kg	pcs	kg
52509	CRTW35	17x19x21x1/2'DR	350	1,2	20	25

Heavy duty cross-handle socket wrench

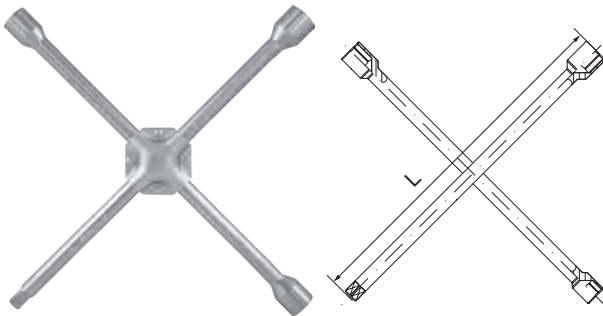

Code	Item No.	Size, mm	L, mm	kg	pcs	kg
52510	CRTW38	17x19x21x1/2'DR	380	1,3	20	27

Heavy duty cross-handle socket wrench with adapter

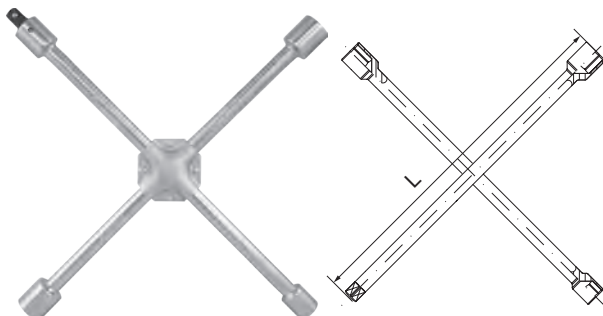

Code	Item No.	Size, mm	L, mm	kg	pcs	kg
52511	CRTW40AD	17x19x21x22*1/2'DR	400	1,4	20	29

* Adapter 19 mm HDRx1/2'DR included.

Tire piston inflator



Code	Item No.
52650	ATIG1

3 function tire gauge









Code	Item No.
52651	ATIG2

Cutting tool

The widest in range tool group, designed to change the shape and size of the workpiece by removing part of the material in the form of cuttings to obtain a finished part or semi-finished product. The cutting tool can be, both manual and machine - for use with the help of mechanization.

TM THORVIK® offers its customers a cutting tool for manual processing of various materials, for example, files, as well as metal twist drills for working with manual mechanized tools and using machine tools.



DIN	According to DIN standart	HSS Co	High-speed steel with cobalt content	TiN	Coating - Titanium Nitride		Allows to process steel
HSS	High-speed steel		The angle at the top of the drill is 118°	Bronze	Bronze coating		Allows to process non-ferrous metals
	High-speed steel without additional coating		The angle at the top of the drill is 135°		Allows to process steel		Allows machining plastics
	Positioning air grinder at the angle of 90°			Positioning air grinder at the angle less then 90°			



Weight of one item



Quantity in the package / shipping box



Packing weight (gross) / shipping box (gross)

FILES AND FILE SETS

The range of TM Thorvik metalwork files are represented by a product line of various profiles and types of notches. High degree of hardening - up to 62 HRC and a stable ratio of tooth height to the notch pitch across the entire working surface provide greater wear resistance of files and allow the use of tools for processing high-hardness materials. Products are equipped with ergonomic two-component handles.

Files



Code	Item No.	Form	Notch type	L1, mm	L2, mm	kg	pcs	kg
52281	MFFS200	Double	Double	200	300	0,15	100	17
52282	MFHS200	Double	Double	200	300	0,15	100	17
52283	MFRS200	Double	Double	200	300	0,09	100	11
52284	MFSS200	Double	Double	200	300	0,1	100	12
52286	MFTS200	Double	Double	200	300	0,15	100	17

File set

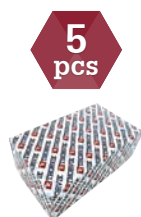

Code	Item No.	kg	pcs	kg
52285	MFSS205	700	20	13
Content:				

Hon for boring hydraulic cylinders

The tool is designed for finishing and removing small scuffs and scratches on the surface of hydraulic cylinders of brake mechanisms of various vehicles.

Hon for boring hydraulic cylinders assembly



Replaceable Hon Bits for Boring Hydraulic Cylinders



Code	Item No.	Working range, mm
53258	BCH3	19-64

Code	Item No.	Size, mm
53259	BCH3	28,5

MOUNTED POINTS

TM Thorvik profile mounted points used in processing of metal products for deburring, scale, clean grinding, beveling and chamfering, processing of corrugated surfaces and grooves. TM Thorvik mounted points are designed to work with straight grinders with a rigid or flexible extended drive.

Universal profile mounted points in a set, Ø 6 mm, 10 pcs



Code	Item No.	kg	pcs	kg
52632	GSK10	0,22	40,00	10,9
Content (10 pcs):				
The shape of the working part	D/T, mm	L, mm	d, mm	
1 Sphere	22/22	49	6	
2 Cylinder	25/12	43	6	
3 Cylinder	24/36	52	6	
4 Cone	18/25	54	6	
5 Dome	20/25	65	6	
6 Dome	19/28	56	6	
7 Cylinder	16/16	58	6	
8 Sphere cylinder	13/26	56	6	
9 Cone	14/28	47	6	
10 Cone cylinder	16/20	48	6	

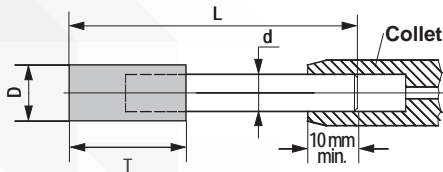

DISKS

Discs are cutting tools based on aluminum oxide (corundum), designed for cutting and grinding work.

Item number: ART.: AGD1156 (left), ART.: AFD115P60 (right)

Name: ДИСК ШЛИФОВАЛЬНЫЙ (left), ДИСК шлифовальный лепестковый (right)

Grit: A24 O BF (left), A60 (right)

Safety standards: (indicated by icons on the right disc)

Specification, cutting conditions, dimensions: 13300 ОБ./МИН. 80 М/С (left), 115 X 6,0 X 22 ММ (left), 115 x 22,2 мм (right)

Processed material: СТАЛЬ (left), (right)

Safety instructions when working with disks:



When working, be sure to use eye and hearing protection, a respirator and protective gloves!



Do not use damaged discs during operation.

Abrasive cutting disc for metal

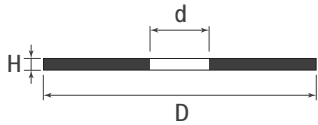

Code	Item No.	D, mm	d, mm	H, mm	Quantity in a package
52366	ACD11512	115	22	1.2	50
52367	ACD11516	115	22	1.6	50
52368	ACD11525	115	22	2.5	50
52370	ACD12512	125	22	1.2	50
52371	ACD12516	125	22	1.6	50
52372	ACD12525	125	22	2.5	50
52775	ACD15012	150	22	1.2	1
52776	ACD15016	150	22	1.6	1
52374	ACD18016	180	22	1.6	50
52375	ACD18020	180	22	2.0	50
52376	ACD18025	180	22	2.5	50
52377	ACD23020	230	22	2.0	50
52378	ACD23025	230	22	2.5	50
52379	ACD23030	230	22	3.0	50
52777	ACD30030	300	25.4	3.0	1
52778	ACD35535	355	25.4	3.5	1
52779	ACD40040	400	32	4.0	1

Grinding abrasive disc for metal

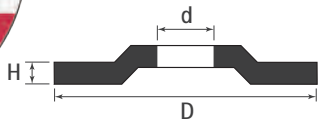

Code	Item No.	D, mm	d, mm	H, mm	Quantity in a package
52369	AGD 11560	115	22	6	25
52373	AGD12560	125	22	6	25

Petal grinding disc

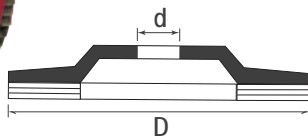

Code	Item No.	D, mm	d, mm	Grit		Quantity in a package
				ISO-6344	Size, mcm	
52380	AFD115P40	115	22.2	p40	400-500	10
52381	AFD115P60	115	22.2	p60	250-315	10
52382	AFD115P80	115	22.2	p80	200-250	10
52383	AFD115P100	115	22.2	p100	125-160	10
52384	AFD125P40	125	22.2	p40	400-500	10
52385	AFD 125P60	125	22.2	p60	250-315	10
52386	AFD125P80	125	22.2	p80	200-250	10
52387	AFD125P100	125	22.2	p100	125-160	10



UTILITY KNIVES

Utility Knife



+ 3 extra blades!

Code	Item No.
52392	GUK197



Spare parts and repair kits are available for this product:

Replaceable blades for household utility knife

Code: 52393; Item No.: GUK197SB

HACKSAW

Hacksaw



- Simple and convenient design;
- Ergonomic rubber grip;
- High quality carbon steel cutting blade, 24 teeth per inch.

Code	Item No.	Blade length, mm
52745	MHS151	150

Hacksaw



- Rugged and lightweight frame design;
- Ergonomic rubber grip;
- The upper part of the frame can be used to store spare blades;
- The ability to install the cutting blade under 45° or 90°;
- Bi-metal cutting blade, 24 teeth per inch, hardness up to 64 HRC.

Code	Item No.	Blade length, mm
52742	MHS301	300

Hacksaw



- Rugged and lightweight heavy duty frame design;
- Ergonomic rubber grip;
- The upper part of the frame can be used to store spare blades;
- The ability to install the cutting blade under 45° or 90°;
- Bi-metal cutting blade, 24 teeth per inch, hardness up to 64 HRC.

Code	Item No.	Blade length, mm
52743	MHS302	300

Hacksaw



- Simple and convenient design;
- Ergonomic rubber grip;
- High quality carbon steel cutting blade, 24 teeth per inch;
- Fast change blade mechanism.

Code	Item No.	Blade length, mm
52744	MHS303	300

Spare blades for hacksaws



■ High quality carbon steel cutting blade, 24 teeth per inch.

Code	Item No.	Blade length, mm	Quantity in a box
52748	MHSB15	150	10
52747	MHSB30	300	10



■ Bi-metal cutting blade, 24 teeth per inch, hardness up to 64 HRC.

Code	Item No.	Blade length, mm	Quantity in a box
52746	MHSB30BM	300	2

DRILLS AND DRILL SETS

TM Thorvik twist metal drill are made from high speed tool steel with a high content of alloying elements, which makes it possible to process materials with high hardness. The geometry of sharpening drills makes it possible to process most well-known materials, such as cast iron, carbon and structural steels, stainless and high-temperature alloys, with high efficiency. TM Thorvik twist drills are manufactured according to DIN 338 type N.

Spiral metal drill HSS

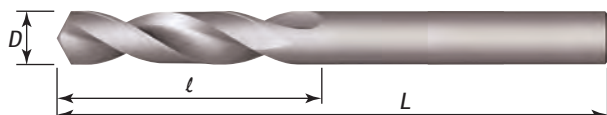

Code	Item No.	D, mm	L, mm	l, mm	Quantity in a packag
52394	TDB010	1,0	34	12	10
52395	TDB015	1,5	40	18	10
52396	TDB020	2,0	49	24	10
52397	TDB025	2,5	57	30	10
52398	TDB030	3,0	61	33	10
52399	TDB032	3,2	65	36	10
52400	TDB035	3,5	70	39	10
52401	TDB040	4,0	75	43	10
52402	TDB042	4,2	75	43	10
52403	TDB045	4,5	80	47	10
52404	TDB048	4,8	86	52	10
52405	TDB050	5,0	86	52	10
52406	TDB055	5,5	93	57	10
52407	TDB060	6,0	93	57	10
52408	TDB065	6,5	101	63	10
52409	TDB070	7,0	109	69	10
52410	TDB075	7,5	109	69	10
52411	TDB080	8,0	117	75	10
52412	TDB085	8,5	117	75	5
52413	TDB090	9,0	125	81	5
52414	TDB095	9,5	125	81	5
52415	TDB100	10,0	133	87	5
52416	TDB105	10,5	133	87	5
52417	TDB110	11,0	142	94	5
52418	TDB115	11,5	142	94	5
52419	TDB120	12,0	151	101	5
52420	TDB125	12,5	151	101	5
52421	TDB130	13,0	151	101	5

Spiral metal drill HSS TiN in blister

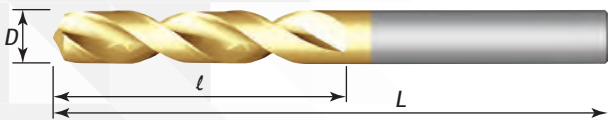
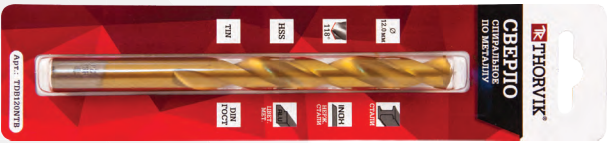

Code	Item No.	D, mm	L, mm	l, mm	Quantity in a package
52422	TDB010NTB	1,0	34	12	2
52423	TDB015NTB	1,5	40	18	2
52424	TDB020NTB	2,0	49	24	2
52425	TDB025NTB	2,5	57	30	2
52426	TDB030NTB	3,0	61	33	1
52427	TDB032NTB	3,2	65	36	1
52428	TDB035NTB	3,5	70	39	1
52429	TDB040NTB	4,0	75	43	1
52430	TDB042NTB	4,2	75	43	1
52431	TDB045NTB	4,5	80	47	1
52432	TDB048NTB	4,8	86	52	1
52433	TDB050NTB	5,0	86	52	1
52434	TDB055NTB	5,5	93	57	1
52435	TDB060NTB	6,0	93	57	1
52436	TDB065NTB	6,5	101	63	1
52437	TDB070NTB	7,0	109	69	1
52438	TDB075NTB	7,5	109	69	1
52439	TDB080NTB	8,0	117	75	1
52440	TDB085NTB	8,5	117	75	1
52441	TDB090NTB	9,0	125	81	1
52442	TDB095NTB	9,5	125	81	1
52443	TDB100NTB	10,0	133	87	1
52444	TDB105NTB	10,5	133	87	1
52445	TDB110NTB	11,0	142	94	1
52446	TDB115NTB	11,5	142	94	1
52447	TDB120NTB	12,0	151	101	1
52448	TDB125NTB	12,5	151	101	1
52449	TDB130NTB	13,0	151	101	1

HSS TiN Twist Drill Bit Sets

Set of spiral drills for metal HSS TiN in a plastic case 6 pcs

6 pcs



Code	Item No.	Quantity in a package
52478	TDBS6	6
Content: 2,0, 3,0, 4,0, 5,0, 6,0, 8,0 mm		

Set of spiral drills for metal HSS TiN in a plastic case 10 pcs

10 pcs



Code	Item No.	Quantity in a package
52479	TDBS10	10
Content: 1,0, 2,0, 3,0, 4,0, 5,0, 6,0, 7,0, 8,0, 9,0, 10,0 mm		

Set of spiral drills for metal HSS TiN in a metal case 13 pcs

13 pcs



Code	Item No.	Quantity in a package
52480	TDBS13	13
Content: 1,5, 2,0, 2,5, 3,0, 3,2, 3,5, 4,0, 4,5, 4,8, 5,0, 5,5, 6,0, 6,5 mm		

Set of spiral drills for metal HSS TiN in a metal case 19 pcs

19 pcs



Code	Item No.	Quantity in a package
52481	TDBS19	19
Content: 1,0, 1,5, 2,0, 2,5, 3,0, 3,5, 4,0, 4,5, 5,0, 5,5, 6,0, 6,5, 7,0, 7,5, 8,0, 8,5, 9,0, 9,5, 10,0 mm		

HSS Co metal twist drill in PVC packaging

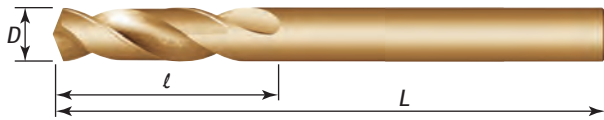

Drill bits $D \geq 13$ mm has shank $\varnothing 13$ mm.

Code	Item No.	D, mm	L, mm	l, mm	Quantity in a package
52450	TDB010K5	1,00	34	12	2
52451	TDB015K5	1,50	40	18	2
52452	TDB020K5	2,00	49	24	2
52453	TDB025K5	2,50	57	30	2
52656	TDB028K5	2,80	61	33	2
52657	TDB029K5	2,90	61	33	2
52454	TDB030K5	3,00	61	33	1
52658	TDB031K5	3,10	65	36	1
52455	TDB032K5	3,20	65	36	1
52659	TDB033K5	3,30	65	36	1
52660	TDB034K5	3,40	70	39	1
52456	TDB035K5	3,50	70	39	1
52661	TDB036K5	3,60	70	39	1
52662	TDB037K5	3,70	70	39	1
52663	TDB038K5	3,80	75	43	1
52664	TDB039K5	3,90	75	43	1
52457	TDB040K5	4,00	75	43	1
52665	TDB041K5	4,10	75	43	1
52458	TDB042K5	4,20	75	43	1
52666	TDB043K5	4,30	80	47	1
52667	TDB044K5	4,40	80	47	1
52459	TDB045K5	4,50	80	47	1
52668	TDB046K5	4,60	80	47	1
52669	TDB047K5	4,70	80	47	1
52460	TDB048K5	4,80	86	52	1
52670	TDB049K5	4,90	86	52	1
52461	TDB050K5	5,00	86	52	1
52671	TDB051K5	5,10	86	52	1
52672	TDB052K5	5,20	86	52	1
52673	TDB053K5	5,30	86	52	1
52674	TDB054K5	5,40	93	57	1
52462	TDB055K5	5,50	93	57	1
52675	TDB056K5	5,60	93	57	1
52676	TDB057K5	5,70	93	57	1
52677	TDB058K5	5,80	93	57	1
52678	TDB059K5	5,90	93	57	1
52463	TDB060K5	6,00	93	57	1
52679	TDB061K5	6,10	101	63	1
52680	TDB062K5	6,20	101	63	1
52681	TDB063K5	6,30	101	63	1
52682	TDB064K5	6,40	101	63	1
52464	TDB065K5	6,50	101	63	1
52683	TDB066K5	6,60	101	63	1
52684	TDB067K5	6,70	101	63	1

Code	Item No.	D, mm	L, mm	l, mm	Quantity in a package
52685	TDB068K5	6,80	109	69	1
52686	TDB069K5	6,90	109	69	1
52465	TDB070K5	7,00	109	69	1
52687	TDB071K5	7,10	109	69	1
52688	TDB072K5	7,20	109	69	1
52689	TDB073K5	7,30	109	69	1
52690	TDB074K5	7,40	109	69	1
52466	TDB075K5	7,50	109	69	1
52691	TDB076K5	7,60	117	75	1
52692	TDB077K5	7,70	117	75	1
52693	TDB078K5	7,80	117	75	1
52694	TDB079K5	7,90	117	75	1
52467	TDB080K5	8,00	117	75	1
52695	TDB081K5	8,10	117	75	1
52696	TDB082K5	8,20	117	75	1
52697	TDB083K5	8,30	117	75	1
52698	TDB084K5	8,40	117	75	1
52468	TDB085K5	8,50	117	75	1
52699	TDB086K5	8,60	125	81	1
52700	TDB087K5	8,70	125	81	1
52701	TDB088K5	8,80	125	81	1
52702	TDB089K5	8,90	125	81	1
52469	TDB090K5	9,00	125	81	1
52703	TDB091K5	9,10	125	81	1
52704	TDB092K5	9,20	125	81	1
52705	TDB093K5	9,30	125	81	1
52706	TDB094K5	9,40	125	81	1
52470	TDB095K5	9,50	125	81	1
52707	TDB096K5	9,60	125	81	1
52708	TDB097K5	9,70	133	87	1
52709	TDB098K5	9,80	133	87	1
52710	TDB099K5	9,90	133	87	1
52471	TDB100K5	10,00	133	87	1
52711	TDB101K5	10,10	133	87	1
52712	TDB102K5	10,20	133	87	1
52713	TDB103K5	10,30	133	87	1
52714	TDB104K5	10,40	133	87	1
52472	TDB105K5	10,50	133	87	1
52715	TDB106K5	10,60	133	87	1
52716	TDB107K5	10,70	142	94	1
52717	TDB108K5	10,80	142	94	1
52718	TDB109K5	10,90	142	94	1
52473	TDB110K5	11,00	142	94	1
52719	TDB111K5	11,10	142	94	1
52720	TDB112K5	11,20	142	94	1
52721	TDB113K5	11,30	142	94	1
52722	TDB114K5	11,40	142	94	1
52474	TDB115K5	11,50	142	94	1
52723	TDB116K5	11,60	142	94	1
52724	TDB117K5	11,70	142	94	1
52725	TDB118K5	11,80	142	94	1
52726	TDB119K5	11,90	151	101	1
52475	TDB120K5	12,00	151	101	1
52727	TDB121K5	12,10	151	101	1
52728	TDB122K5	12,20	151	101	1
52729	TDB123K5	12,30	151	101	1
52730	TDB124K5	12,40	151	101	1
52476	TDB125K5	12,50	151	101	1
52731	TDB126K5	12,60	151	101	1
52732	TDB127K5	12,70	151	101	1
52733	TDB128K5	12,80	151	101	1
52734	TDB129K5	12,90	151	101	1
52477	TDB130K5	13,00	151	101	1
52735	TDB140K5	14,00	160	108	1
52736	TDB150K5	15,00	169	114	1
52737	TDB160K5	16,00	178	120	1
52738	TDB170K5	17,00	184	125	1
52739	TDB180K5	18,00	191	130	1
52740	TDB190K5	19,00	198	135	1
52741	TDB200K5	20,00	205	140	1



Set of spiral drills for metal HSS Co

13 pcs



19 pcs



25 pcs



Code	Item No.	Quantity in a package
52897	TDBS13K5	13
Content: 1.5, 2, 2.5, 3, 3.5, 4, 4.5, 5, 5.5, 6, 6.5 mm		

Code	Item No.	Quantity in a package
52898	TDBS19K5	19
Content: 1, 1.5, 2, 2.5, 3, 3.5, 4, 4.5, 5, 5.5, 6, 6.5, 7, 7.5, 8, 8.5, 9, 9.5, 10 mm		

Code	Item No.	Quantity in a package
52899	TDBS25K5	25
Content: 1, 1.5, 2, 2.5, 3, 3.5, 4, 4.5, 5, 5.5, 6, 6.5, 7, 7.5, 8, 8.5, 9, 9.5, 10, 10.5, 11, 11.5, 12, 12.5, 13 mm		

THREADING

Die D-COMBO round, for hand use

M/MF HSS-G 6g

60° DIN EN 22568

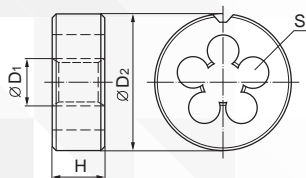

Code	Item No.	Thread	D1, mm	D2, mm	H, mm	S	kg	pcs	kg
52828	MD305	M3x0.5	3,0	20,0	5,0	4	0,01	200	2,4
52829	MD407	M4x0.7	4,0	20,0	5,0	4	0,008	200	2,1
52830	MD508	M5x0.8	5,0	20,0	7,0	4	0,012	200	2,8
52831	MD61	M6x1.0	6,0	20,0	7,0	4	0,01	200	2,5
52832	MD71	M7x1.0	7,0	25,0	9,0	4	0,026	280	7,7
52833	MD81	MF8x1.0	8,0	25,0	9,0	4	0,025	280	7,6
52834	MD8125	M8x1.25	8,0	25,0	9,0	4	0,025	280	7,6
52835	MD101	MF10x1.0	10,0	30,0	11,0	4	0,037	280	10,4
052836	MD10125	MF10x1.25	10,0	30,0	11,0	4	0,037	280	10,8
52837	MD1015	M10x1.5	10,0	30,0	11,0	4	0,038	280	11
52838	MD12125	MF12x1.25	12,0	38,0	10,0	4	0,058	40	2,8
52839	MD1215	MF12x1.5	12,0	38,0	10,0	4	0,058	40	2,8
52840	MD12175	M12x1.75	12,0	38,0	14,0	4	0,08	40	3,7
52841	MD14125	MF14x1.25	14,0	38,0	10,0	4	0,058	40	2,8
52842	MD1415	MF14x1.5	14,0	38,0	10,0	4	0,058	40	2,8
52843	MD142	M14x2.0	14,0	38,0	14,0	4	0,08	40	3,7
52844	MD1615	MF16x1.5	16,0	45,0	14,0	4	0,108	40	4,8

Die set D-COMBO round, for hand use M3-M12, HSS

8 pcs.



Code	Item No.	kg	pcs	kg
52885	MDS8	0,45	50	23,5
Content:				
Dies III25x9 mm, 7 pcs.: M3, M4, M5, M6, M8 (MD8125), M10, M12;				
Dies-holder (DH259);				
Metal case.				

3 pass taps and round dies set COMBO M3-M12, HSS-G, for hand use

32 pcs.



Code	Item No.	kg	pcs	kg
52887	MTDS32	1,47	10	15,7

Content:
 Sets (3 pcs.) three-way taps, 7 pcs.: M3, M4, M5, M6, M8, M10, M12;
 Taps holder M1-M12 (art.TH1);
 Dies III25x9 mm, 7 pcs.: M3, M4, M5, M6, M8 (MD8125), M10, M12;
 Dies holder (DH259);
 Slotted screwdriver;
 Thread gauge;
 Metal case.

Die D-DRIVE round, for hand use

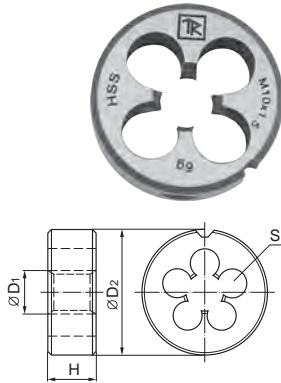

M	HSS	R	6g	DIN EN 22568	
---	-----	---	----	--------------	--

Code	Item No.	Thread	D1, mm	D2, mm	H, mm	S	kg	pcs	kg
52859	MDG305	M3x0.5	3,0	25,0	9,0	4	0,056	200	11,6
52860	MDG407	M4x0.7	4,0	25,0	9,0	4	0,056	200	11,6
52861	MDG508	M5x0.8	5,0	25,0	9,0	4	0,053	200	11
52862	MDG61	M6x1.0	6,0	25,0	9,0	4	0,054	200	11,2
52863	MDG8125	MF8x1.0	8,0	25,0	9,0	4	0,049	200	10,2
52864	MDG1015	M10x1.5	10,0	25,0	9,0	4	0,048	200	10

2 pass taps set T-COMBO, 2 pcs for hand use

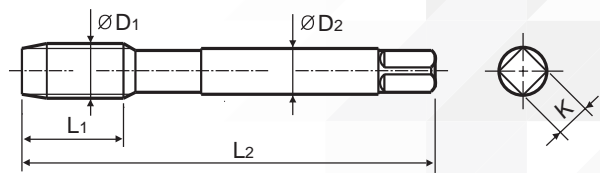

M/MF	HSS-G	2D
R	6H	DIN 352
	FORM A/C	

Code	Item No.	Thread	D1, mm	D2, mm	L1, mm	L2, mm	K, mm		kg	pcs	kg
052811	MT305S2	M3x0.5	3,00	3,50	11,00	40,00	2,70	2.5	0,012	320	3,9
052812	MT407S2	M4x0.7	4,00	4,50	13,00	45,00	3,40	3.3	0,016	320	5,6
052813	MT508S2	M5x0.8	5,0	6,00	16,00	50,00	4,90	4.2	0,024	320	8,2
052814	MT61S2	M6x1.0	6,0	6,00	19,00	56,00	4,90	5.0	0,028	320	9,4
052815	MT71S2	M7x1.0	7,0	6,00	19,00	63,00	4,90	6.0	0,043	80	3,9
052816	MT81S2	MF8x1.0	8,0	6,00	22,00	63,00	4,90	7.0	0,041	80	3,8
052817	MT8125S2	M8x1.25	8,0	6,00	22,00	63,00	4,90	6.8	0,043	80	3,9
052818	MT101S2	MF10x1.0	10,0	7,00	20,00	63,00	5,50	9	0,054	80	4,8
052819	MT10125S2	MF10x1.25	10,0	7,00	24,00	70,00	5,50	8.8	0,056	80	5
052820	MT1015S2	M10x1.5	10,0	7,00	24,00	70,00	5,50	8.5	0,056	80	5
052821	MT12125S2	MF12x1.25	12,0	9,00	22,00	70,00	7,00	10.8	0,081	80	7
052822	MT1215S2	MF12x1.5	12,0	9,00	22,00	70,00	7,00	10.5	0,081	80	7
052823	MT12175S2	M12x1.75	12,0	9,00	28,00	75,00	7,00	10.2	0,085	80	7,5
052824	MT14125S2	MF14x1.25	14,0	11,00	22,00	70,00	9,00	12.8	0,133	40	5,8
052825	MT1415S2	MF14x1.5	14,0	11,00	22,00	70,00	9,00	12.5	0,13	40	5,7
052826	MT142S2	M14x2.0	14,0	11,00	30,00	80,00	9,00	12.0	0,143	40	6,2
052827	MT1615S2	MF16x1.5	16,0	12,00	22,00	70,00	9,00	14.5	0,15	40	6,5

3 pass taps set T-COMBO M3-M12, HSS-G 22 pcs for hand use

22 pcs.



Code	Item No.	kg	pcs	kg
52886	MTS22	0,704	25	18,6
Content:				
Three pass taps, kit 3 pcs., sizes M3, M4, M5, M6, M8, M10, M12;				
Adjustable hand tap wrench M1-M12 (item no. TH1);				
Metal case.				

Hand/machine tip T-DRIVE with spiral point for through hole + guide

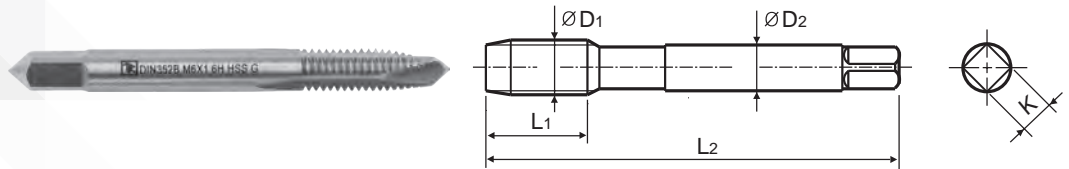

M/MF	HSS	2D
R	6H	
	DIN 371/374	
FORM C		

Code	Item No.	Thread	D1, mm	D2, mm	L1, mm	L2, mm	K, mm		kg	pcs	kg
052845	MTG305SP	M3x0.5	3,0	3,50	11,00	40,00	2,70	2,5	0,056	200	11,7
052846	MTG407SP	M4x0.7	4,0	4,50	13,00	45,00	3,40	3,3	0,057	200	11,8
052847	MTG508SP	M5x0.8	5,0	6,00	16,00	50,00	4,90	4,2	0,062	200	12,9
052848	MTG61SP	M6x1.0	6,0	6,00	19,00	56,00	4,90	5,0	0,065	200	13,4
052849	MTG8125SP	M8x1.25	8,0	6,00	22,00	63,00	4,90	6,8	0,069	200	13,8
052850	MTG1015SP	M10x1.5	10,0	7,00	24,00	70,00	5,50	8,5	0,095	102	9,7
052851	MTG12175SP	M12x1.75	12,0	9,00	28,00	75,00	7,00	10,2	0,11	102	11,2

Hand/machine tip T-DRIVE, right spiral flute, for blind hole + guide

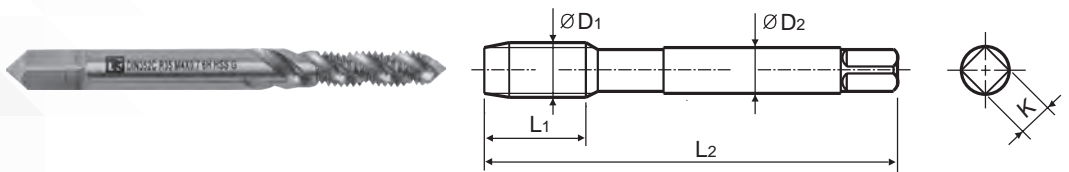

M/MF	HSS-S	2D
R	6H	Tilt angle 35°
	DIN 371/374	FORM C

Code	Item No.	Thread	D1, mm	D2, mm	L1, mm	L2, mm	K, mm		kg	pcs	kg
052852	MTG305SF	M3x0.5	3,0	3,50	11,00	40,00	2,70	2,5	0,056	200	11,6
052853	MTG407SF	M4x0.7	4,0	4,50	13,00	45,00	3,40	3,3	0,056	200	11,7
052854	MTG508SF	M5x0.8	5,0	6,00	16,00	50,00	4,90	4,2	0,061	200	12,7
052855	MTG61SF	M6x1.0	6,0	6,00	19,00	56,00	4,90	5,0	0,063	200	13
052856	MTG8125SF	M8x1.25	8,0	6,00	22,00	63,00	4,90	6,8	0,068	200	14
052857	MTG1015SF	M10x1.5	10,0	7,00	24,00	70,00	5,50	8,5	0,093	102	10
052858	MTG12175SF	M12x1.75	12,0	9,00	28,00	75,00	7,00	10,2	0,106	102	11,3

Adjustable hand tap wrench



Code	Item No.	For taps	kg	pcs	kg
52865	TH1	M1-10	0,114	200	23,8
52866	TH2	M4-12	0,295	60	18,7
52867	TH3	M5-20	0,626	30	19,8

Adjustable hand tap ratchet wrench



Code	Item No.	For taps	kg	pcs	kg
52878	RTH1	M3-10	0,211	60	13,7
52879	RTH2	M5-12	0,303	60	19,2

Adjustable hand tap ratchet long wrench



Code	Item No.	For taps	kg	pcs	kg
52880	RTH10	M3-10	0,301	60	19,1
52881	RTH20	M5-12	0,434	32	14,9

Adjustable hand tap wrench, fast lock



Code	Item No.	For taps	kg	pcs	kg
52882	TTH1	M3-6	0,072	160	12,6
52883	TTH2	M5-8	0,1	120	13
52884	TTH3	M6-12	0,158	120	20

Round had die holder



Code	Item No.	For dies	kg	pcs	kg
52868	DH205	Ø20x5 mm	0,089	300	27,7
52869	DH207	Ø20x7 mm	0,089	300	27,7
52870	DH259	Ø25x9 mm	0,141	160	23,5
52873	DH3810	Ø38x10 mm	0,394	50	20,7
52871	DH3011	Ø30x11 mm	0,226	100	23,6
52872	DH3814	Ø38x14 mm	0,384	50	20,2
52874	DH4514	Ø45x14 mm	0,6	30	19

TAPER EXTRACTORS

Screw extractor set



Code	Item No.	
52877	SEA5S	
Content:		
M3-M6; M6-M8; M8-M11; M11-M14; M14-M18.		
Plastic case.		
Recommendations for preparing a hole for dismantling a threaded joint		
For thread	Drilling diameter	Drilling depth
M3-M6	1,8	7
M6-M8	3,2	10
M8-M11	4,5	13
M11-M14	6,5	16
M14-M18	8,5	21

Measuring tool

A group of devices and gauges that allow to establish quantitative ratios of any parameters in comparison with a standard is called a measuring tool. These products are mainly used to define geometrical parameters of objects, but can also be associated with the determination of the numerical characteristics of a variety of quantities: mass, induction, spectral.

TM THORVIK® offers its customers products for line and angle measurements such as measuring tape, protractor and torque tools.



TORQUE WRENCHES

Torque wrenches*



Code	Item No.	Drive size	Working torque, Nm
52363	TW14224	1/4" DR	2-24
52364	TW381911	3/8" DR	19-110
52365	TW122821	1/2" DR	28-210

* Wrenches are entered into the Unified State Register of Measuring Instruments (USRS)



Spare parts and repair kits are available for this product:

Torque Wrench Repair Kit for TW14224

Code: 52505; Item No.: TW14224RK

Torque Wrench Repair Kit for TW381911

Code: 52504; Item No.: TW381911RK

Torque Wrench Repair Kit for TW122821

Code: 52503; Item No.: TW122821RK

TORQUE MULTIPLIERS

Labor save wrench



1" DR 1:58 3800 Nm

Code	Item No.	DR	Gear ratio	Maximum torque, Nm	L, mm	kg
52752	LSW1	1	1:58	3800	270	6.5

Content: Labor save wrench, handle, HEX L-key, manual and warranty card, plastic case.

Labor save wrench



1" DR 1:58 3800 Nm

Code	Item No.	DR	Gear ratio	Maximum torque, Nm	L, mm	Extension length, mm	kg
52753	LSW2	1	1:58	3800	270	255	7.75

Content: Content: Labor save wrench; handle; extension; socket 1"DR: 32, 33 mm; manual and warranty card, plastic case.

Labor save wrench

1" DR
1:58
3800 Nm



Code	Item No.	DR	Gear ratio	Maximum torque, Nm	L, mm	Extension length, mm	kg
52754	LSW3	1	1:58	3800	310	255	8.25

Content: Labor save wrench; handle; extension; socket 1"DR: 32, 33 mm; manual and warranty card, plastic case.



4 and 6-point flank sockets 1"DR for labor save wrench on [page 18-19](#).

ANGLE GAUGES

Angle gauge



Code	Item No.
52354	ATAG12

MEASURING TAPES

Measuring tape in rubber body



Code	Item No.	Length, m
52388	SMT316	3
52389	SMT519	5
52894	SMT7525	7.5
52895	SMT1025	10

Measuring tape with magnet capture and autostop, rubber body



Code	Item No.	Length, m
52390	SMT316AM	3
52391	SMT519AM	5
52896	SMT7525AM	7.5

THREAD GAUGES

Thread gauges for external threads

20 pcs.

Code	Item No.
52875	PG20S



Combined thread gauges for external and internal threads

14 pcs.

Code	Item No.
52876	PG14SC



Spanners	1-12 стр.
Combination wrenches and sets of them	2-3 стр.
Combination wrenches and sets of them. Series ARC	3-5 стр.
Open end wrenches and sets of them	5 стр.
Open end wrenches and sets of them. Series ARC	6-7 стр.
Double ring end wrenches and sets of them	8 стр.
Double ring end wrenches and sets of them. Series ARC.....	8-10 стр.
Double end flare nut wrenches and sets of them	10 стр.
Double end flare nut wrenches and sets of them. Series ARC	10-11 стр.
Adjustable wrenches	11 стр.
Pipe wrenches	12 стр.
Sockets	13-19 стр.
Flank sockets 1/4"DR	14-15 стр.
Flank sockets 1/4"DR	16-18 стр.
Spark plug sockets	18 стр.
Flank sockets 1"DR.....	18-19 стр.
Handles, universal joints, ratchets	20-22 стр.
Handles	21 стр.
Ratchet handles	21 стр.
Extensions	22 стр.
Universal joints	22 стр.
Tool sets	23-34 стр.
Screwdrivers	35-45 стр.
Screwdrivers and sets of them	36-37 стр.
Insulated screwdrivers and sets of them	38 стр.
Pocket screwdriver 4 in 1	38 стр.
Hex keys and sets of them	39-43 стр.
Torx® keys and sets of them	43-45 стр.
Pliers	46-48 стр.
Combination pliers	47 стр.
Diagonal cutting pliers.....	47 стр.
Long nose pliers	47 стр.
Box joint pliers	47 стр.
Internal/external pliers	48 стр.
Impactor tool	49-51 стр.
Hammers	50 стр.
Sledgehammer	51 стр.
Mallets	51 стр.
Pneumatic tools	52-60 стр.
Pneumatic impact wrenches	53-55 стр.
Air ratchet wrench	55 стр.
Air drill	56 стр.
Air die grinder	57 стр.
Air angle grinders	58 стр.
Air hammers	58 стр.
Air blow guns	59 стр.
Air hoses for pneumatic tools	60 стр.
Automotive tools	61-79 стр.
Universal tool	65-66 стр.
Chassis repair and maintenance tool	66-73 стр.
Body repair and maintenance tool	73-74 стр.
Engine repair and maintenance tool	74-77 стр.
Auxiliary tool	78 стр.
Tool for tyre repair	78-79 стр.
Cutting tool	80-91 стр.
Files and file sets	81-83 стр.
Utility knives	84 стр.
Hacksaw	84-85 стр.
Drills and drill sets	85-88 стр.
Threading	88-91 стр.
Taper extractors	91 стр.
Measuring tool	92-94 стр.
Torque wrenches	93 стр.
Angle gauges	93-94 стр.
Angle	94 стр.
Measuring tapes	94 стр.
Thread Gauges	94 стр.
The contents	95 стр.



LIFETIME WARRANTY

All THORVIK hand tools are covered by a lifetime warranty against breakage due to defects in materials or workmanship for the expected life of the tool, except as otherwise specified. If you found any defects in a product, return it to the THORVIK distributor where you purchased it.

EXCLUSIONS

- Adapters
- Ordinary wear and tear of normal using (e.g. bits, drill bits, files, saw blades)
- Worn plastic grips and handles
- Tools showing signs of “hammering” damage, abusing, overloading and incorrect using
- Damage from cutting edges or gripping teeth resulting from use on hardened materials

LIMITED TIME WARRANTY

THORVIK warrants tools consisting parts designed to wear such as ratchet handles, ratchet wrenches, pneumatic and hydraulic equipment for a period of one (1) year from date of purchase with proof of purchase, applies to these tools.

For many of tools we offer spare parts to maxims lifetime.

Torque wrenches are designed to be re-calibrated after 1,000 cycles or 1 year (whichever comes first).

This warranty does not cover any problems caused by misuse, abuse, neglect, accidents, modification, poor or incorrect maintenance and improper storage of the tools.



TR THORVIK®
RELIABLE TOOLS

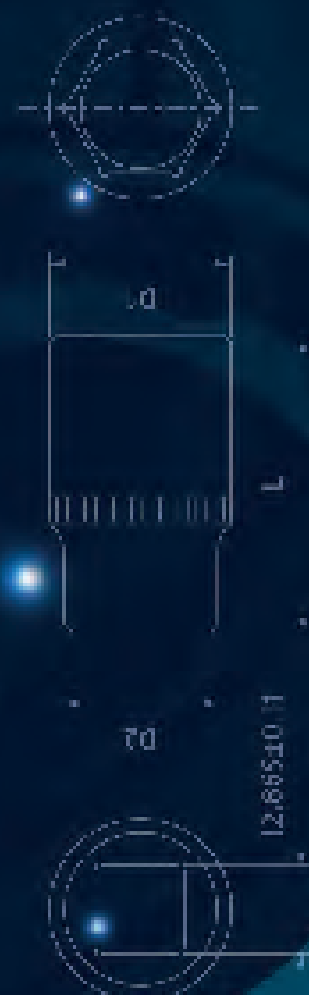

Thorvik
European Central Warehouse
B.A.D.S. JSC

Ateities str. 30G, Kaunas LT-52163

Tel.: (+370 37) 337842

Fax: (+370 37) 337842

E-mail: info@thorviktools.eu

www.thorviktools.eu

1 11 10 01
1 0100 1
01 10 1
1 0 1
10 0 0
1 01 1 10